

treesse

DESIGN FOR  
LIFESTYLE

DESIGN E TECNOLOGIA  
PER IL VOSTRO RELAX

Design and technology for your relaxation  
Design et technologie pour votre détente

LIFESTYLE  
COME VOCAZIONE

Lifestyle as a calling  
Le lifestyle comme vocation

Design by

SADLER

Concept + graphic project  
[adhocspaziocreativo.it](http://adhocspaziocreativo.it)

Edition  
Nov. 2022

Gruppo Tre S.p.a.  
S.S. Cassia Km 36,400  
Zona industriale Settevene  
01036 Nepi (VI) Italia  
+39 0761 527242  
[info@gruppotres.it](mailto:info@gruppotres.it)

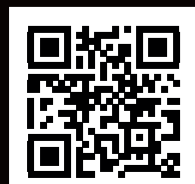

pool

# SADLER SUPERQUARZ

L. 220 X P. 220 X H. 90 cm

IL BORDO A SFIORO, SOTTOLINEATO DA UNA RAFFINATA LUCE PERIMETRALE. BOCCHETTE IDROMASSAGGIO ALTAMENTE PERFORMANTI, RESE UNICHE DA UN DESIGN TIPICAMENTE ITALIANO. LA NUOVA MINIPISCINA SUPERQUARZ NASCE DA UN LUNGO LAVORO DI PROGETTAZIONE CHE HA PERMESSO DI UNIRE, PER LA PRIMA VOLTA, ELEMENTI TECNICI ED ESTETICI DI ASSOLUTA ECCELLENZA.

The infinity edge is highlighted by a refined perimeter light. With highly performing hydromassage nozzles that are unique thanks to their typically Italian design. The new Superquarz is based on extensive design work that allowed to combine technical and aesthetic elements of absolute excellence for the first time ever.

Le débordement, souligné par une lumière raffinée sur le pourtour. Des buses d'hydromassage hautement performantes et au design typiquement italien qui les rend uniques. La nouvelle mini-piscine Superquarz est le fruit d'un long travail de conception qui a permis d'unir, pour la première fois, des éléments techniques et esthétiques d'une excellence absolue.



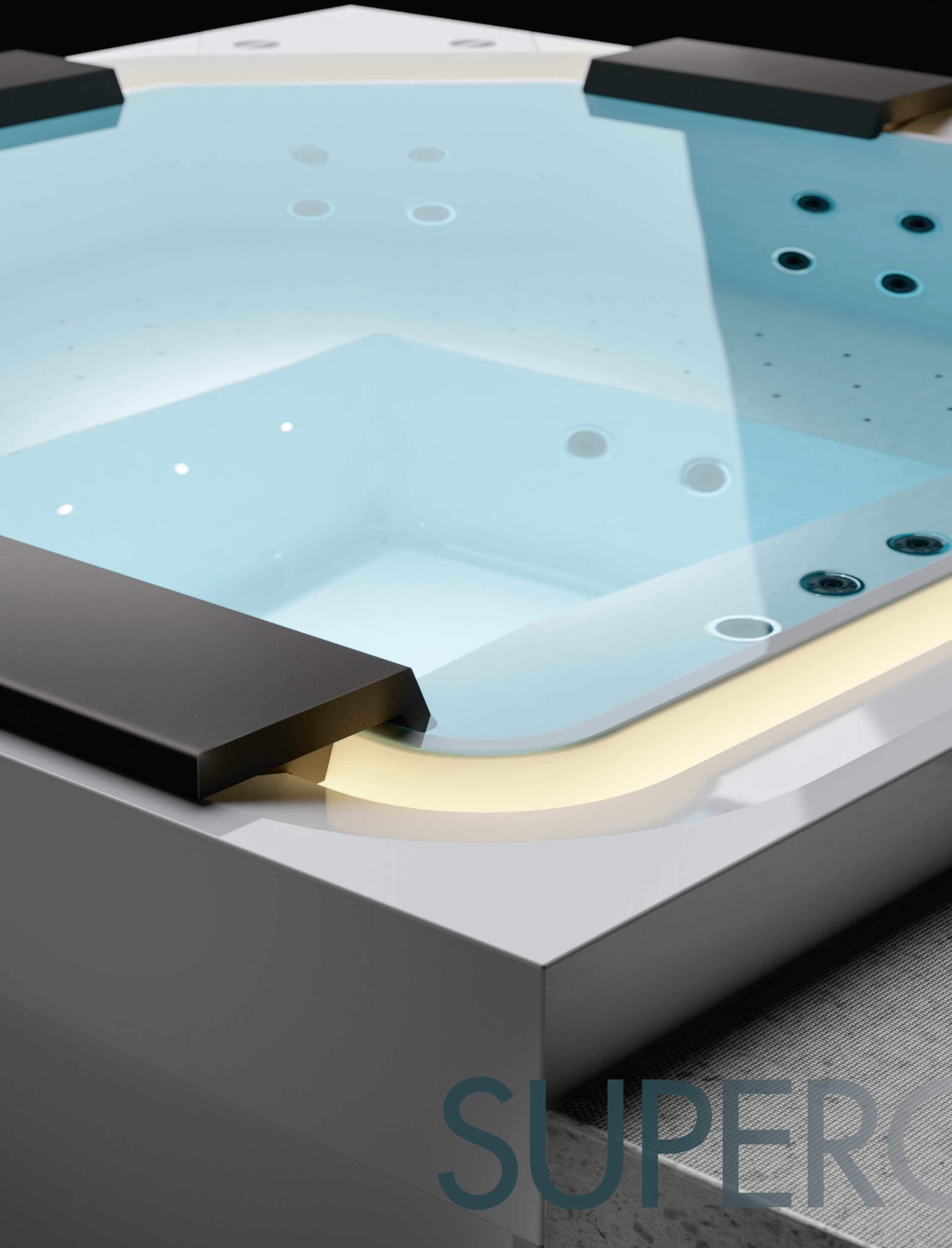

## SUPERQUARZ PLUS

L. 220 X P. 220 X H. 90 cm

OGNI DETTAGLIO FUNZIONALE, OGNI NUOVA SOLUZIONE PROGETTUALE SONO STATI RESI POSSIBILI DALL'ESPERIENZA E DALLA SOLIDITÀ DI UN'AZIENDA CON OLTRE QUARANT'ANNI DI STORIA. IL DESIGN, ELEGANTE E MINIMALISTA, RAPPRESENTA CON ORGOGLIO LO STILE ESCLUSIVO TIPICO DELLE MINIPISCINE TREESSE. UNA NUOVA MINIPISCINA PROGETTATA CON UN SOLO OBIETTIVO: RIDEFINIRE IL CONCETTO DI LEISURE, PER SODDISFARE UNA CLIENTELA SEMPRE PIÙ ESIGENTE.

Every functional detail, every new design solution has been made possible by the experience and solidity of a company with over forty years of history. The elegant, minimalist design proudly represents the exclusive style typical of Treesse mini-pools. A new mini-pool designed with a single objective: to redefine the concept of leisure in order to satisfy an increasingly demanding clientele.

Chaque détail fonctionnel et chaque nouvelle solution conceptuelle sont devenus possibles grâce à l'expérience et à la solidité d'une entreprise forte de plus de quarante ans d'histoire. Le design, élégant et minimaliste, représente avec orgueil le style exclusif typique des mini-piscines Treesse. Une nouvelle mini-piscine conçue avec un seul objectif : redéfinir le concept de loisir afin de satisfaire une clientèle de plus en plus exigeante.



## SUPERQUARZ

L. 220 X P. 220 X H. 90 cm



Colore pannello  
Panel color  
Couleur du panneau



Bianco  
White  
Blanc

# SUPERQUARZ

ghost  
plus

AN EXCLUSIVE TRESSE PATENT

SADLER  
HEAVEN

L. 210 X P. 210 X H. 86 cm

ABBIAMO PRESO LA NOSTRA LINEA PIÙ AMATA E L'ABBIAMO RESA ANCORA PIÙ SPECIALE.  
GODITI I NUOVI SCHIENALI, ANCORA PIÙ COMODI, E LE DIMENSIONI PIÙ AMPIE.  
SORPRENDITI DELLA SEDUTA PIÙ BASSA, CHE CONSENTE ALL'ACQUA DI ARRIVARE FINO ALLE SPALLE,  
REGALANDO UN NUOVO RELAX...

LA NUOVA MINIPISCINA HEAVEN RIPRENDE E PERFEZIONA L'ESPERIENZA UNICA  
DELLA LINEA GHOST PLUS CON NUOVI ACCORGIMENTI E DETTAGLI.  
PER NOI, I DETTAGLI HANNO SEMPRE LA MASSIMA IMPORTANZA.

We took our most beloved line and made it even more special.

Enjoy the new, even more comfortable backrests and the larger dimensions.

Be pleasantly surprised by the lower seat which lets the water reach your shoulders,  
making it even more relaxing...

The new Heaven mini-pool takes up and then perfects the unique experience  
of the Ghost Plus line with new features and details.

We have always considered the smallest details with the utmost importance.

Nous avons pris la plus appréciée de nos lignes et nous l'avons rendue encore plus spéciale.

Profitez des nouveaux dossiers, encore plus confortables, et des dimensions plus généreuses.

Laissez-vous surprendre par l'assise plus basse qui permet à l'eau d'arriver jusqu'aux épaules,  
en offrant un nouveau relax...

La nouvelle mini-piscine Heaven s'inspire et perfectionne l'expérience unique  
de la ligne Ghost Plus avec de nouveaux moyens et de nouveaux détails.

Pour nous, ce sont toujours les détails qui font la différence.

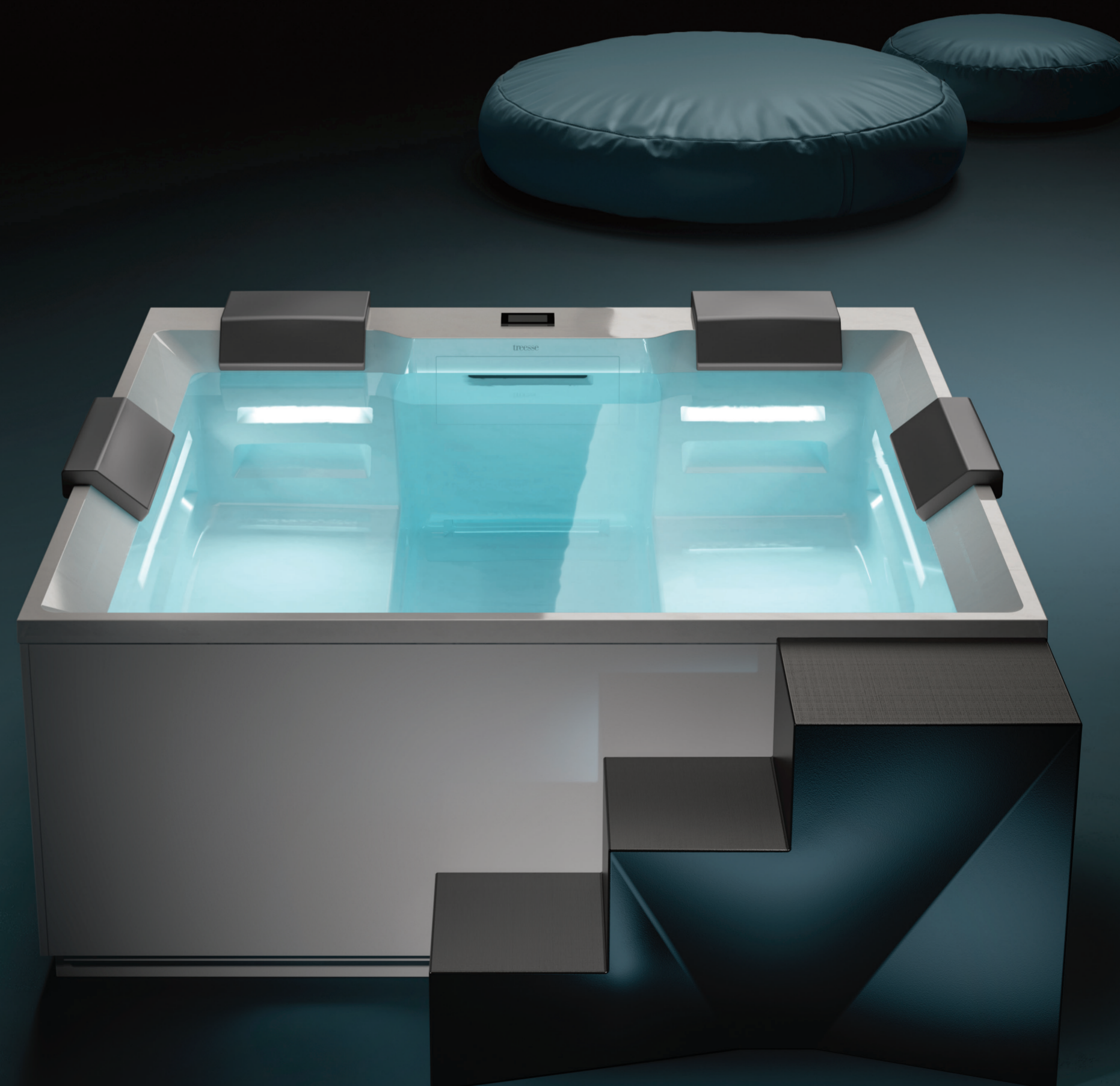

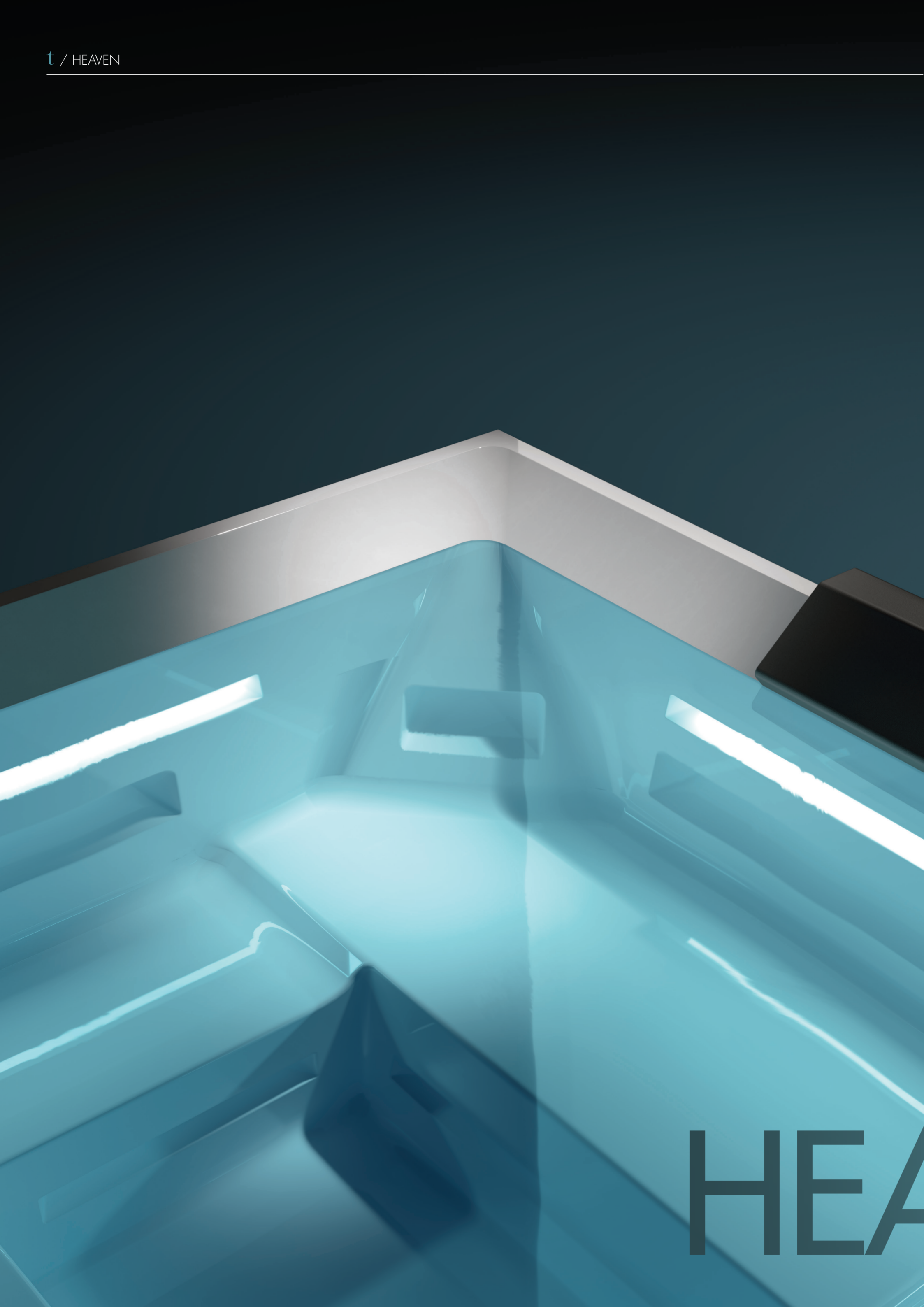

HEAVEN

L. 210 X P. 210 X H. 86 cm



Colori pannello  
Panel colors  
Couleurs du panneau



Bianco  
White  
Blanc

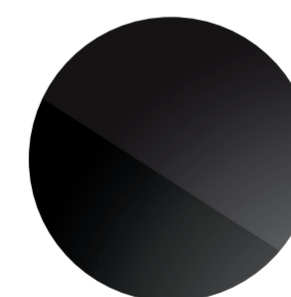

Nero  
Black  
Noir

HEAVEN

# SADLER AQUARUN

L. 510 X P. 235 X H. 142 cm

L'ACQUA È RELAX, SOGNO, È ASSAPORARE IL MOMENTO. MA È ANCHE SPORT, ENERGIA, FORZA! CON AQUARUN SI PUÒ GODERE DI UN'ESPERIENZA DI NUOTO COINVOLGENTE, DIROMPENTE, ADATTA ALLO SPORTIVO PROFESSIONISTA COME AL SEMPLICE APPASSIONATO. DAL PUNTO DI VISTA TECNICO, AQUARUN È UN PRODOTTO INNOVATIVO, CON PRESTAZIONI SUPERIORI E UNO SPAZIO PIÙ AMPIO E CONFORTEVOLE RISPETTO ALLE ALTRE VASCHE PER IL NUOTO CONTROCORRENTE: BEN 235 CENTIMETRI DI LARGHEZZA.

Water is relaxation, dreaming; it's savouring the moment. But it's also sport, energy, strength! Aquarun lets you enjoy an immersive, breakthrough swimming experience, suitable for both professional athletes and simple aficionados.

From a technical point of view, Aquarun is an innovative product with superior performance and is larger and has more comfortable space than the other pools for counter-current swimming: an impressive 235 cm in width.

L'eau, c'est la détente, le rêve, c'est profiter du moment présent. Mais c'est aussi le sport, l'énergie, la force ! Aquarun permet de vivre une expérience de nage enveloppante, dynamique, adaptée au sportif professionnel tout comme au simple passionné. Du point de vue technique, Aquarun est un produit innovant, avec des prestations supérieures et un espace plus grand et confortable que les autres vasques pour la nage contre-courant: 235 centimètres de large.



# AQUARUN

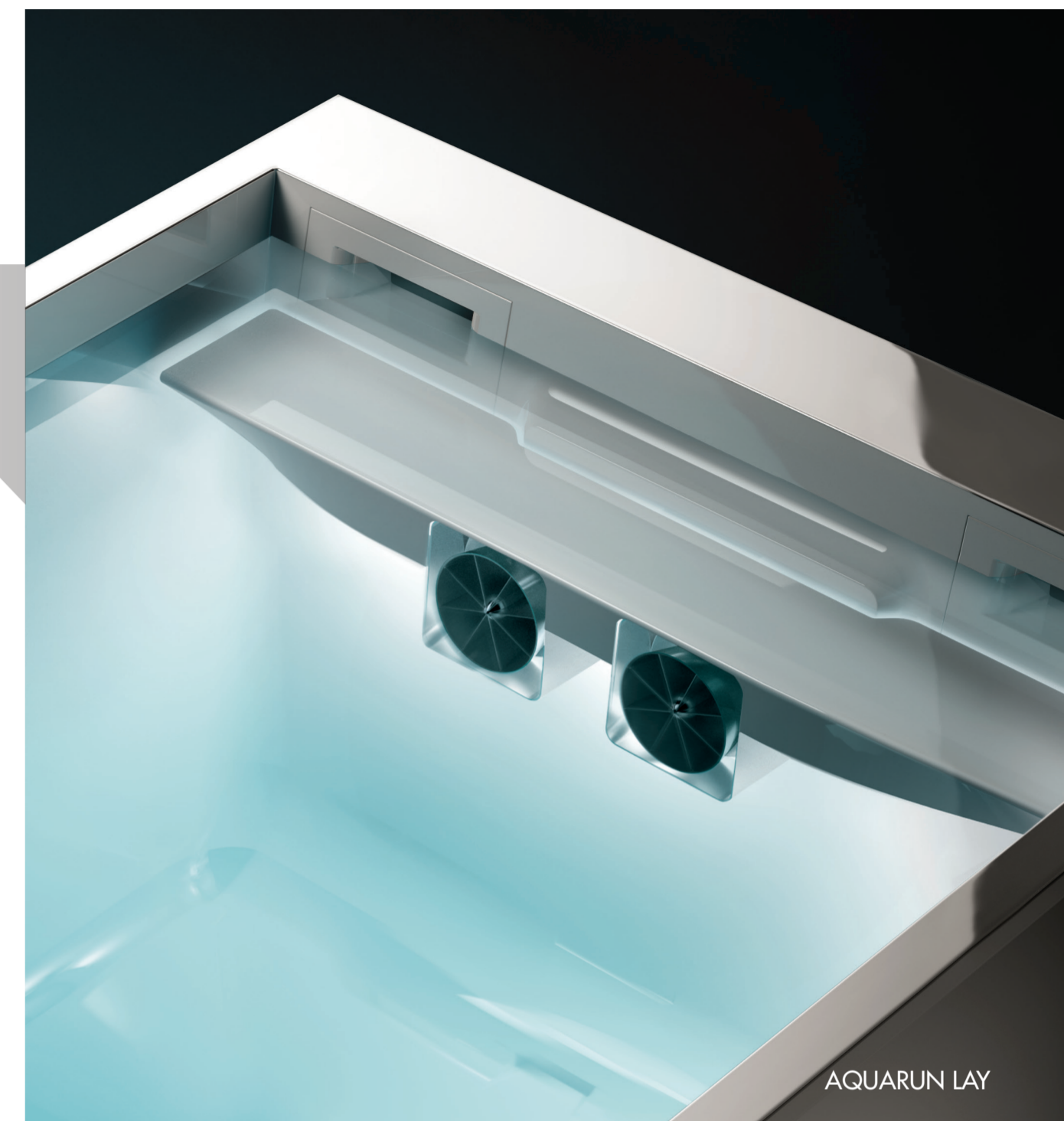
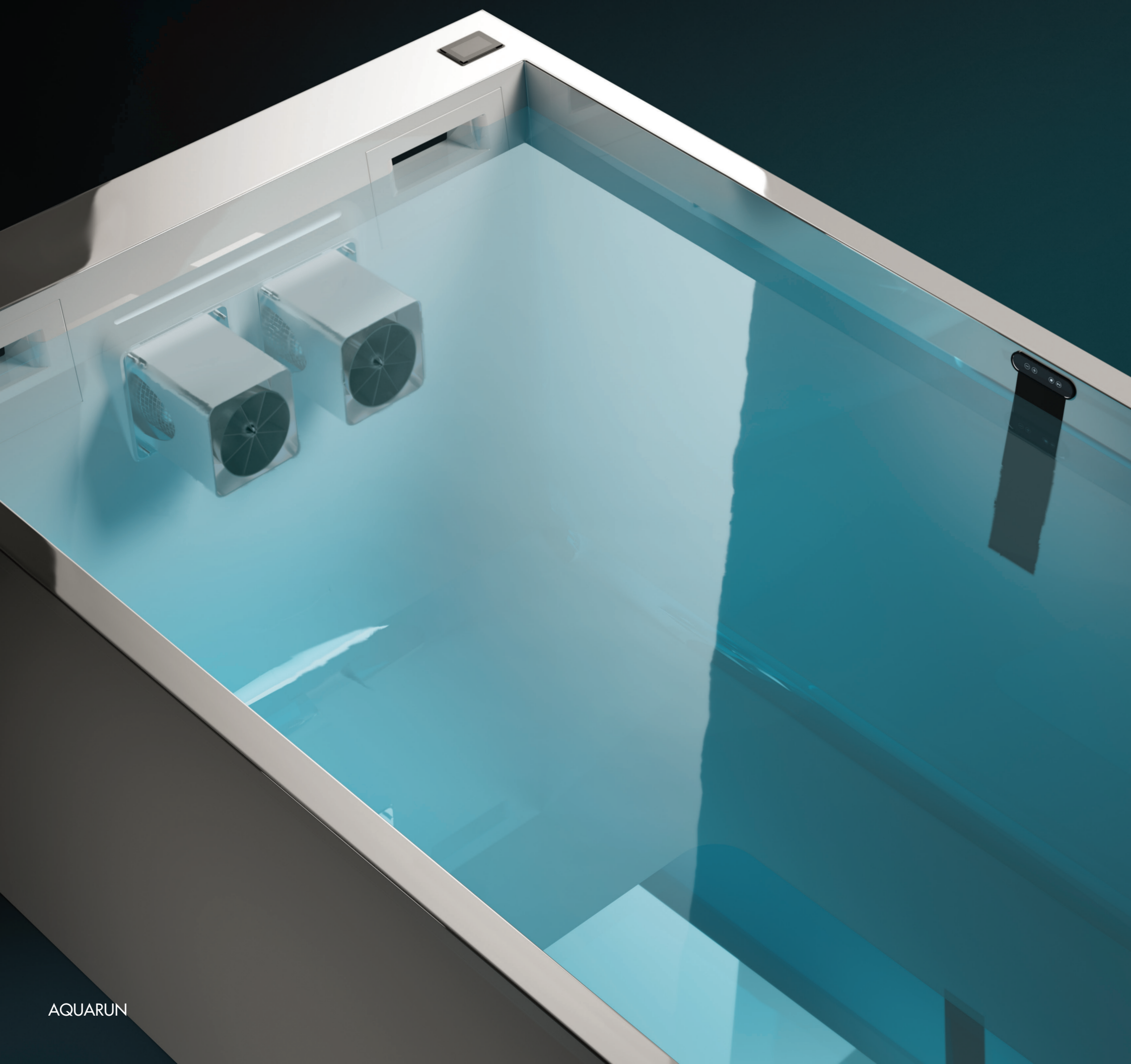

IL MONDO AQUARUN SI ESPANDE.  
 IL NUOVO CARTER RENDE LA VASCA PER NUOTO CONTROCORRENTE PIÙ BELLA E PERFORMANTE.  
 NASCONDE LE TURBINE A VISTA, INTEGRANDOSI PERFETTAMENTE CON LA STRUTTURA.  
 A LIVELLO FUNZIONALE SI TRASFORMA IN UN PICCOLO PIANO DI SEDUTA O DI APPOGGIO, CHE RENDE AQUARUN PIÙ COMODA PER IL NUOTATORE.  
 IL CARTER È FACILMENTE APRIBILE PER PERMETTERE CONTROLLI E MANUTENZIONI.  
 IL NUOVO ELEMENTO HA ISPIRATO ANCHE UN MIGLIORAMENTO ESTETICO: SOTTO LA SUPERFICIE DEL CARTER SONO NASCOSTI TRE PUNTI LUCE.  
 I FASCI LUMINOSI, FILTRANDO, CREANO UNO SCENOGRAFICO ALONE DI LUCE ZENITALE NELL'ACQUA.

The Aquarun world is expanding.  
 The new casing makes the countercurrent swimming pool even more beautiful and performing. It hides the turbines in sight, perfectly integrating with the structure.  
 At a functional level, it transforms into a small seat or support surface, making Aquarun more comfortable for the swimmer. The casing can be easily opened for any checks and maintenance. The new element has also inspired an aesthetic improvement: three light points have been hidden below the casing's surface.  
 The filtered light beams create a spectacular halo of crowning light in the water.

Le monde Aquarun s'élargit.  
 Le nouveau carter rend la vasque de nage contre-courant plus belle et performante. Il cache les turbines visibles tout en s'intégrant parfaitement à la structure.  
 D'un point de vue fonctionnel, il se transforme en un petit plan d'assise ou d'appui, qui rend Aquarun plus pratique pour le nageur. Le carter s'ouvre facilement pour permettre les contrôles et entretiens. Le nouvel élément a également inspiré une amélioration esthétique : sous la surface du carter se cachent trois points de lumière.  
 Les faisceaux lumineux, tout en filtrant, créent un halo théâtral de lumière zénithale dans l'eau.





Turbine  
Turbines  
Turbines

OLTRE ALLE DIMENSIONI, C'È TANTO ALTRO CHE RENDE AQUARUN COSÌ PERFORMANTE. IL MOVIMENTO DELL'ACQUA È PIÙ POTENTE E FACILE DA REGOLARE, GRAZIE ALLE SPECIALI TURBINE CHE LO ALIMENTANO. LA FORMA INTERNA ASSECONDA IL FLUSSO DELL'ACQUA E LO SPECCHIO SUL FONDO PERMETTE DI CONTROLLARE IL MOVIMENTO PER UN ALLENAMENTO PIÙ EFFICACE.

It's not only the size that makes Aquarun so effective. The movement of the water is more powerful and easier to adjust thanks to the special turbines that feed it. The internal shape follows the flow of the water and the mirror on the bottom allows you to check your movements for more effective training.

Au-delà des dimensions, Aquarun dispose de bien d'autres atouts qui la rendent performante. Le mouvement de l'eau est plus puissant et facile à régler, grâce aux turbines spéciales qui l'alimentent. La forme interne accompagne le flux de l'eau et le miroir sur le fond permet de contrôler le mouvement pour un entraînement plus efficace.

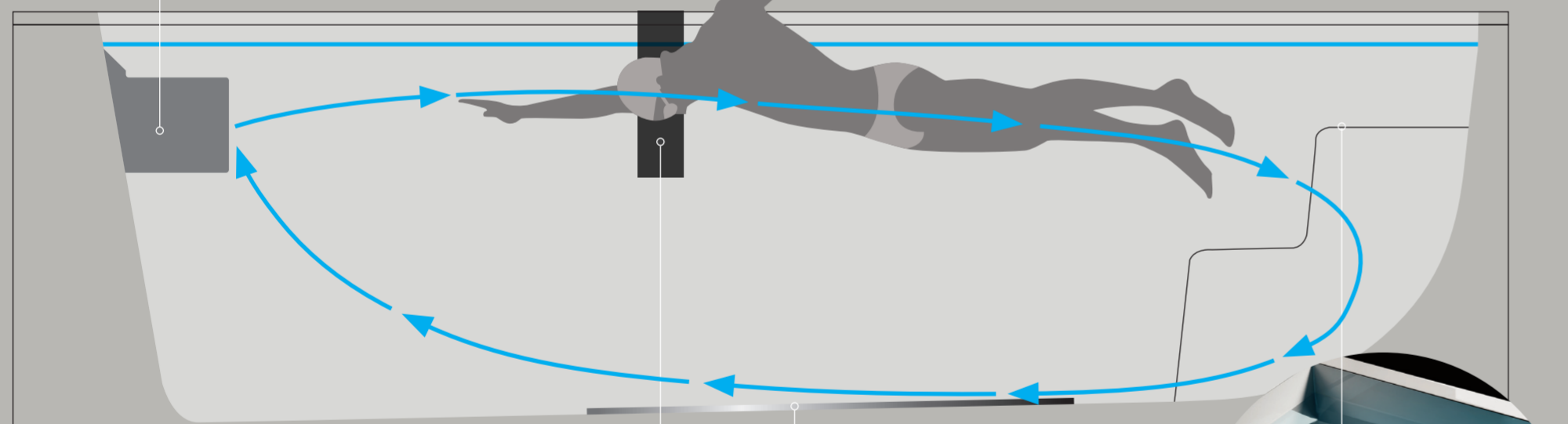

Scalini interni  
Internal steps  
Marches internes

Comando  
Control  
Commandes

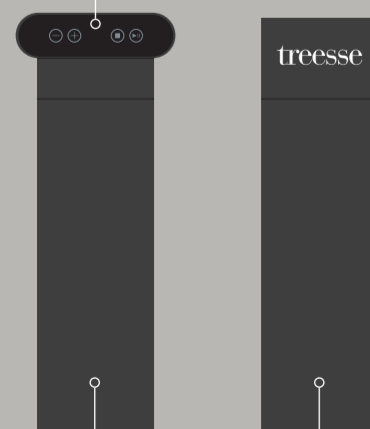

Posizione nuotatore  
Swimmer position  
Position du nageur

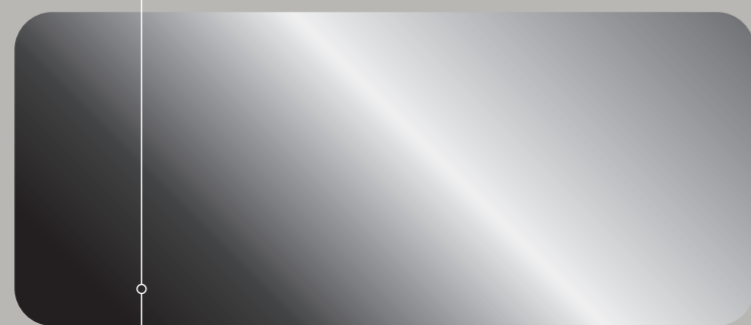

Superficie riflettente  
Reflective surface  
Surface réfléchissante

## AQUARUN

L. 510 X P. 235 X H. 142 cm



## AQUARUN LAY

L. 510 X P. 235 X H. 142 cm



IL DESIGN È UNA CARATTERISTICA IRRINUNCIABILE DI OGNI NOSTRO PRODOTTO. ABBIAMO SCELTO UNO STILE ESSENZIALE ARRICCHITO DI ELEMENTI FUNZIONALI, COME I DOPPI GRADINI DI ACCESSO E DI USCITA DALL'ACQUA. UN NUOVO MODO DI VIVERE IL NUOTO, ANCHE INDOOR E SENZA GLI SPAZI DI UNA PISCINA CLASSICA.

Design is an essential feature of all our products. We opt for an essential style enriched with functional elements, such as the double entry and exit steps from the water. A new way to experience swimming, even indoors and without the space needed for a classic pool.

Le design est une caractéristique indispensable de chacun de nos produits. Nous avons choisi un style épuré enrichi d'éléments fonctionnels, comme les double marches pour entrer et sortir de l'eau. Voilà une nouvelle façon de vivre la natation, en intérieur aussi et sans l'encombrement d'une piscine classique.

Colore pannello  
Panel color  
Couleur du panneau



Bianco  
White  
Blanc

# SADLER THRONE

A L. 125 X P. 40 X H. 81 cm

A+B L. 165 X P. 40 X H. 108 cm

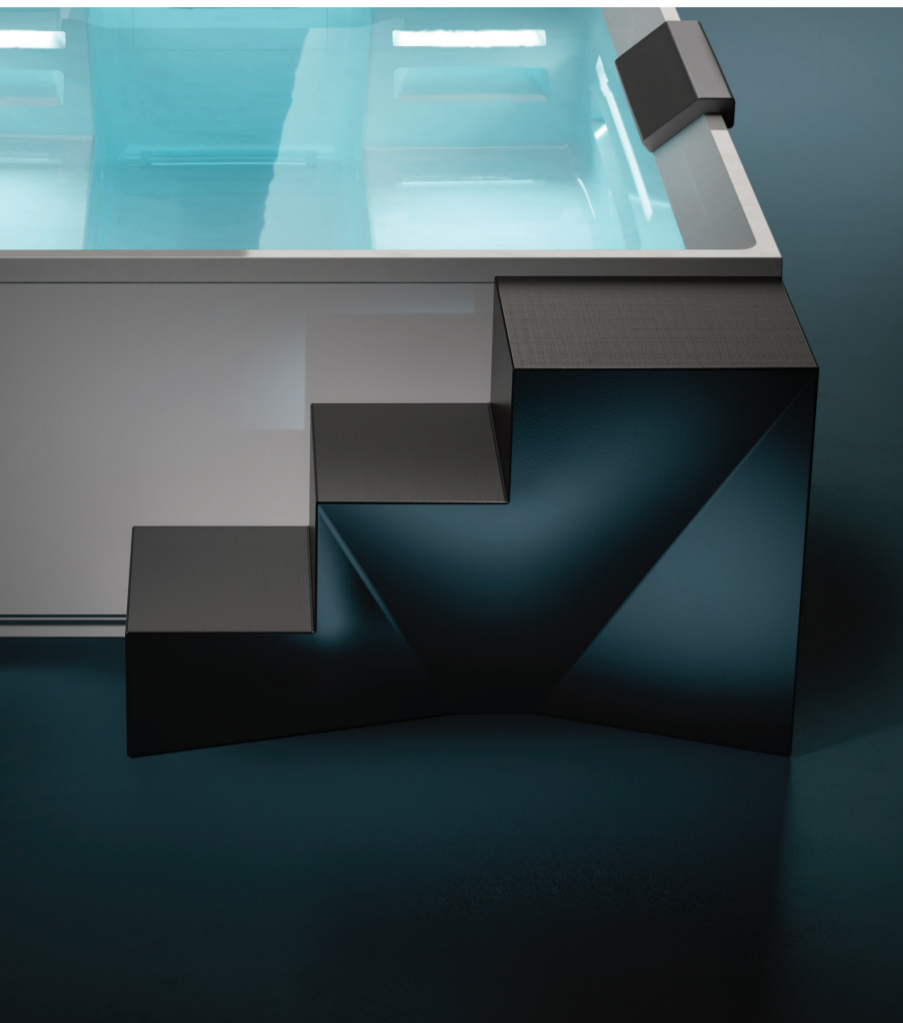

TI PRESENTIAMO UN NUOVO SISTEMA DI ACCESSO ALLE MINIPISCINE TREESSE: UN COMPLEMENTO PERFETTO SIA DAL PUNTO DI VISTA ESTETICO CHE FUNZIONALE. THRONE È BELLA: È UN SISTEMA DAL DESIGN ELEGANTE, DISPONIBILE IN DIVERSI COLORI. È MODULARE, PER ADATTARSI ALLA TUA MINIPISCINA E AI TUOI SPAZI DI INSTALLAZIONE.

We would like to present a new Treesse mini-pool access system: a perfect complement from both an aesthetic and functional point of view. Throne is beautiful with its elegant design, and the system is available in different colours. It is modular in order to adapt to your mini-pool and installation spaces.

Nous vous présentons un nouveau système d'accès aux mini-piscines Treesse : un complément parfait à la fois du point de vue esthétique et fonctionnel. Throne est beau : ce système au design élégant est disponible dans différentes couleurs. Il est modulable, pour s'adapter à votre mini-piscine et à vos espaces d'installation.

THRONE È SICURA E FUNZIONALE. È REALIZZATA IN MATERIALE TERMOPLASTICO E DOTATA DI UNA SPECIALE TEXTURE ANTISCIVOLO. HA CARATTERISTICHE TECNICHE DI PESO E STABILITÀ APPOSITAMENTE STUDIATE PER UNIRE SICUREZZA E MANEGGEVOLEZZA. PREPARATI A SALIRE I GRADINI PER TUFFARTI NELL'ESPERIENZA TREESSE PRIMA ANCORA DI TOCCARE L'ACQUA.

Throne is safe and functional.

It is made of thermoplastic material and has a special anti-slip texture. Its technical weight and stability characteristics are specially designed to combine safety and handling. Get ready to climb the steps to dive into the Treesse experience, before even touching the water.

Throne est sûr et fonctionnel.

Il est réalisé dans un matériau thermoplastique et est doté d'une texture spéciale antidérapante. Ses caractéristiques techniques de poids et de stabilité sont étudiées spécialement pour allier sécurité et maniabilité. Préparez-vous à monter les marches pour plonger dans l'expérience treesse avant même d'entrer dans l'eau.



## MODULI\_ITEMS\_MODULES

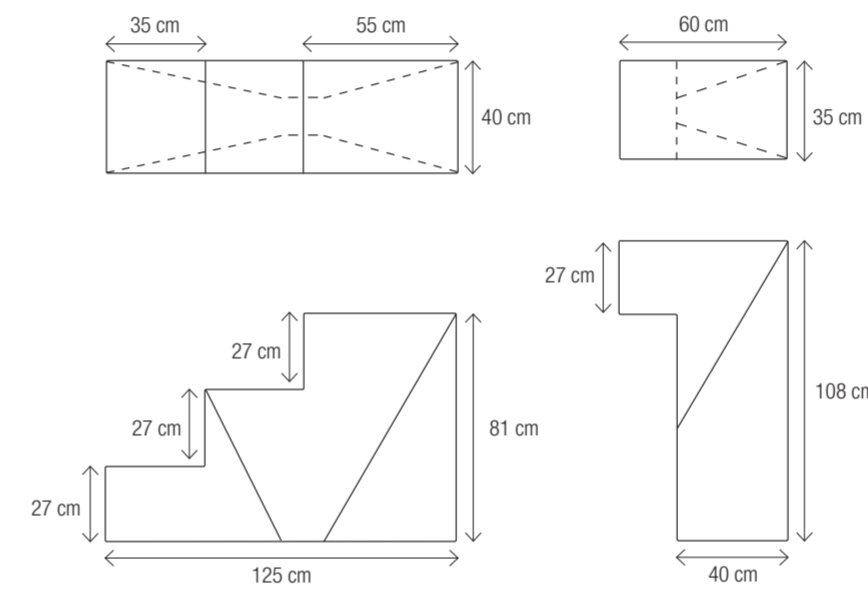
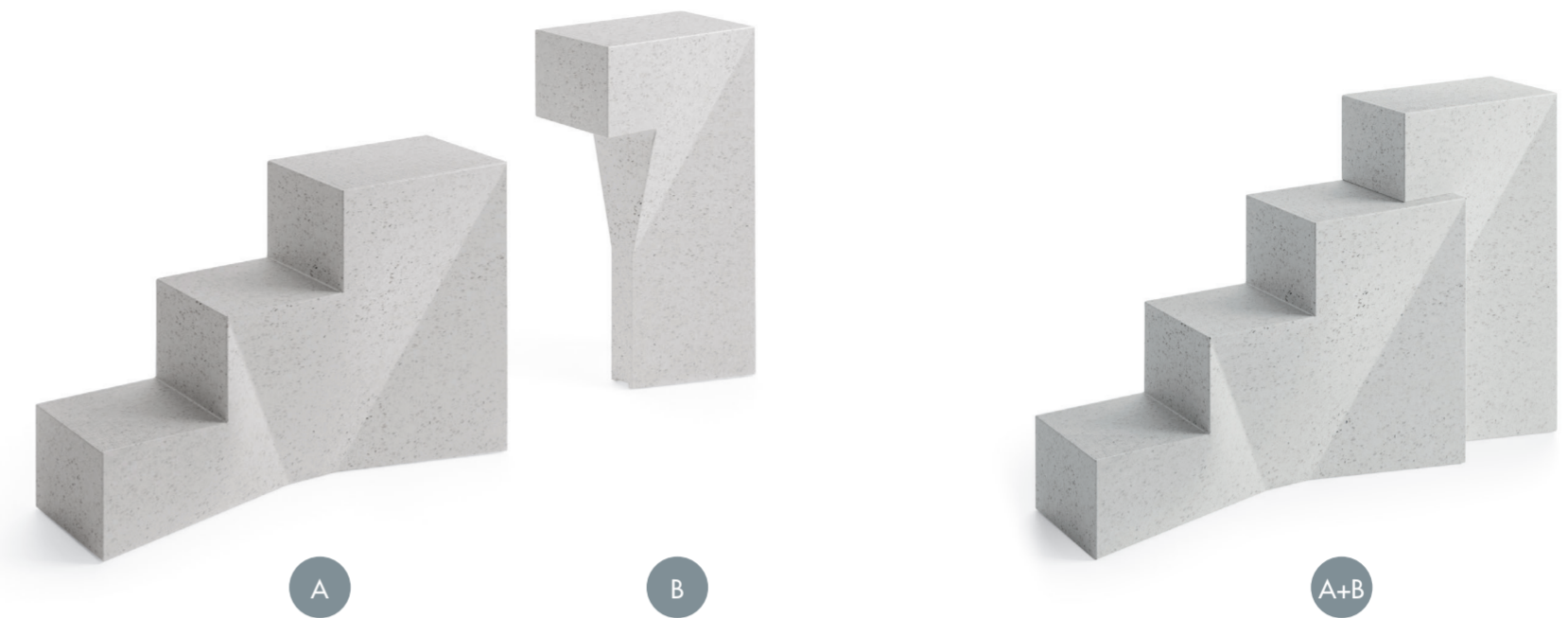

Esempi di componibilità  
Examples of modularity  
Exemples de composition

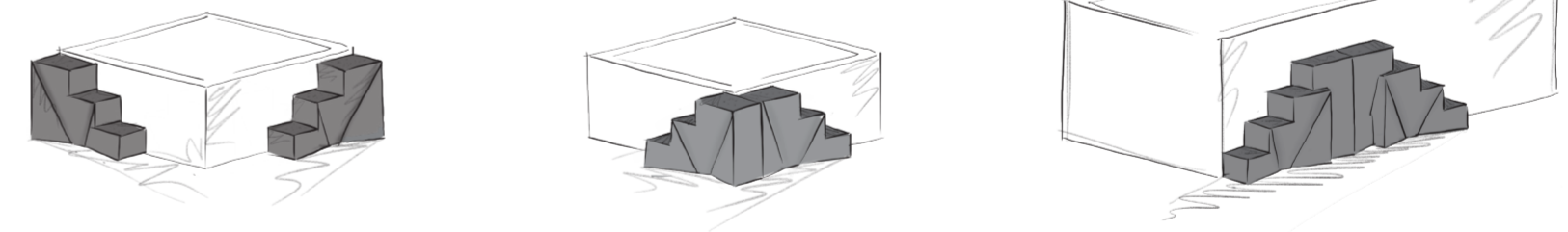

## COLORI\_COLORS\_COULEURS

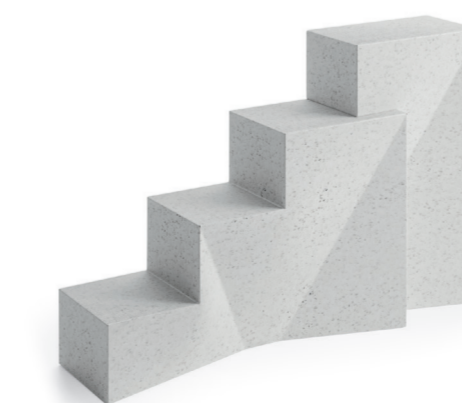

Bianco granito  
Granite white  
Blanc granit



Grigio grafite  
Graphite grey  
Gris graphite

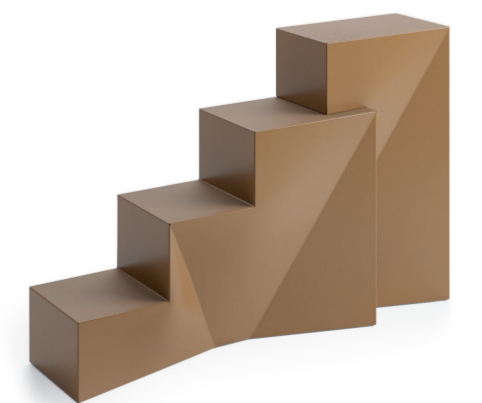

Marrone sabbia  
Sand brown  
Marron sable

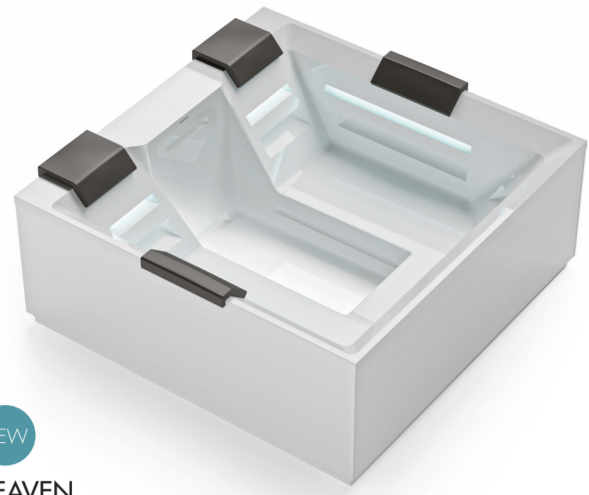

**HEAVEN**  
L. 210 X P. 210 X H. 86 cm



**PHANTOM**  
L. 235 X P. 235 X H. 98 cm



**MUSE GP**  
L. 280 X P. 235 X H. 98 cm



**MAYA GP**  
L. 260 X P. 205 X H. 95 cm

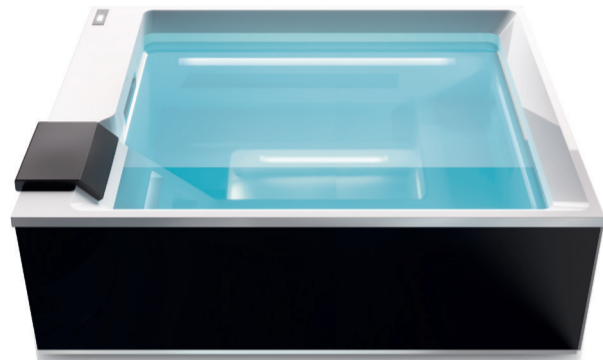

**SHADOW**  
L. 200 X P. 160 X H. 82 cm



**ZEN**  
L. 280 X P. 235 X H. 85 cm



**ZEN ACTIVE**  
L. 300 X P. 235 X H. 85 cm



**REST**  
L. 240 X P. 195 X H. 85 cm



**WAVE**  
L. 235 X P. 235 X H. 98 cm



**MUSE**  
L. 280 X P. 235 X H. 98 cm



**MAYA**  
L. 260 X P. 205 X H. 95 cm

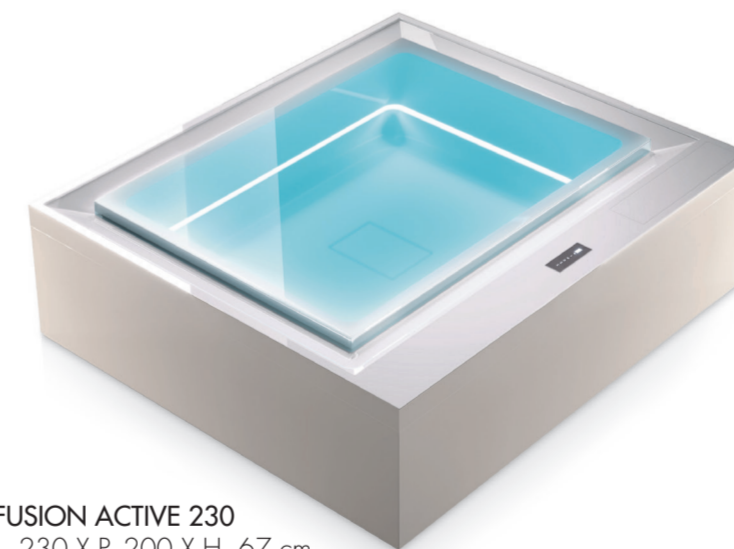

**FUSION ACTIVE 230**  
L. 230 X P. 200 X H. 67 cm



**FUSION SPA 230**  
L. 230 X P. 180 X H. 67 cm



**FUSION SPA 231**  
L. 230 X P. 150 X H. 67 cm



**FUSION SPA 200**  
Ø 200 x H. 67 cm



**FUSION SPA 220**  
L. 220 X P. 120 X H. 67 cm



**AQUARUN**  
L. 510 X P. 235 X H. 142 cm

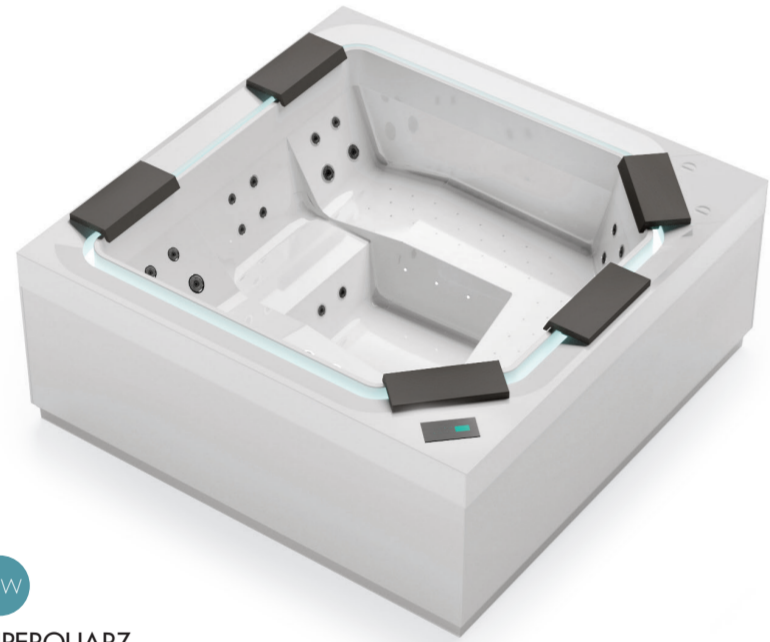

**SUPERQUARZ**  
L. 220 X P. 220 X H. 90 cm



**QUARZ LIGHT 212**  
L. 212 X P. 190 X H. 90 cm



**QUARZ LIGHT 235**  
L. 235 X P. 215 X H. 90 cm

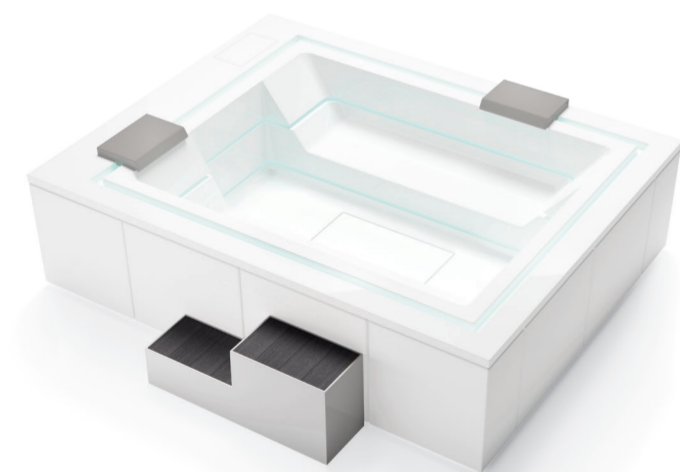

**STEP-BOX\***  
120

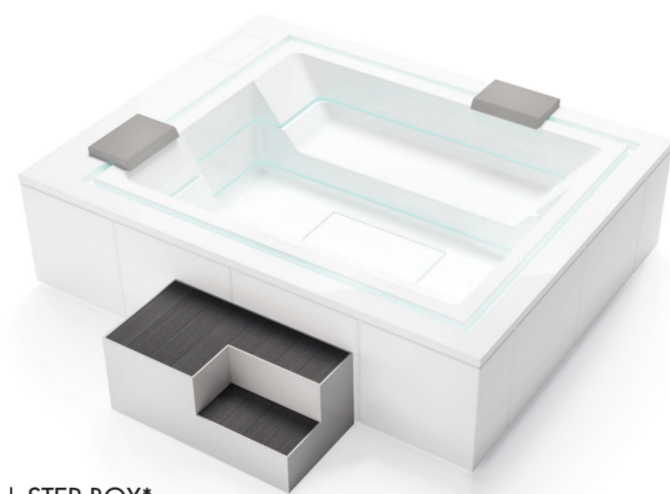

**STEP-BOX\***  
115

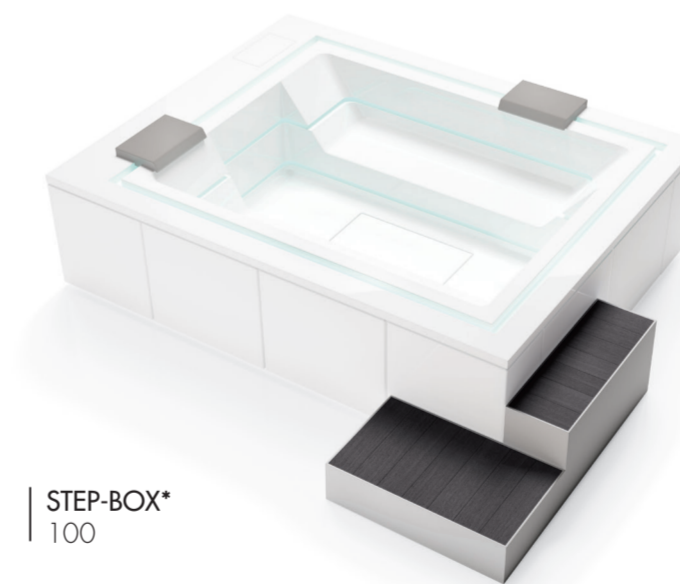

**STEP-BOX\***  
100

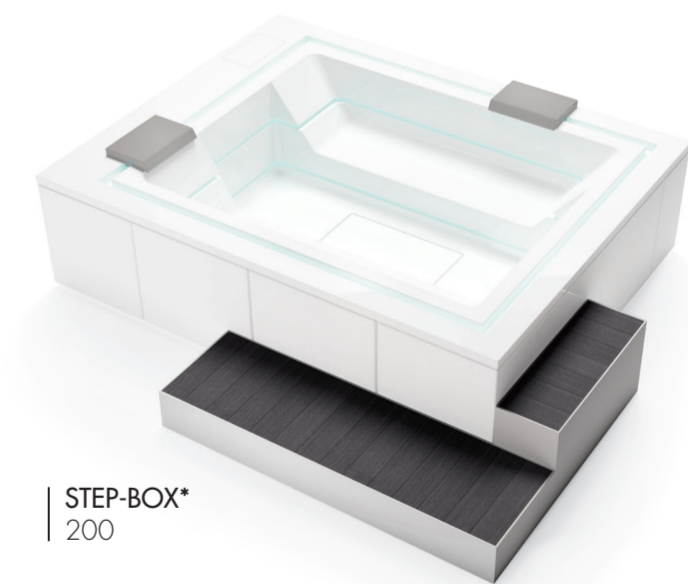

**STEP-BOX\***  
200

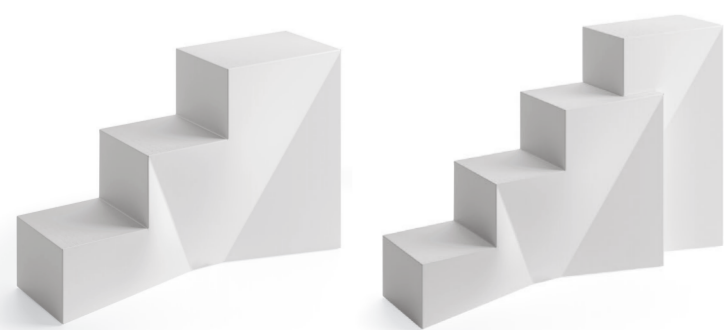

**THRONE (A)**  
L. 125 X P. 40 X H. 81 cm

**THRONE (A + B)**  
L. 165 X P. 40 X H. 108 cm



**BIG BANG\*** Sistema audio - Sound system - Système audio  
Ø 55 X H. 55 cm

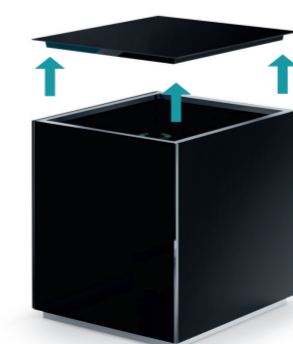

**SPA PACK\***  
L. 60 X P. 80 X H. 75 cm

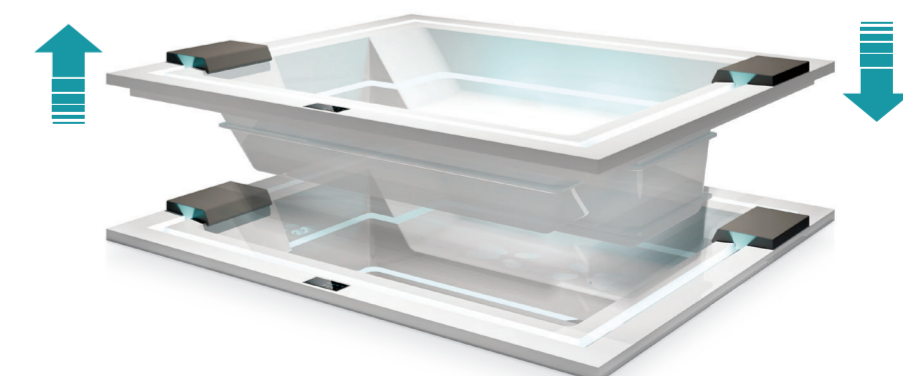

**SOLLEVATORE AUTOMATICO\*** - Automatic lifting mechanism - Dispositif de soulèvement automatique

\* Disponibile in abbinamento con Minipiscine Ghost e Ghost Plus - Available to match our Ghost and Ghost Plus minipools - Disponible en combinaison avec les Mini-piscines Ghost et Ghost Plus

gruppotreesse.it

