

artwork

ITALIAN HERITAGE

BY

KERASAN

artwork

ITALIAN HERITAGE
BY
KERASAN

Artwork Italian Heritage è un nuovo concept che abbina al design più audace la massima versatilità creativa e funzionale. La collezione di sculture in ceramica nata dall'esperienza di Kerasan, da oltre sessant'anni leader nella produzione della ceramica d'arredo, presenta oggetti d'arte capaci di preservare la massima funzionalità per arricchire il piacere dell'abitare. Nascono così forme inedite, capaci di rompere con coraggio ogni schema prestabilito e di portare il linguaggio della scultura nell'interior design per ogni ambiente della casa. Le ceramiche Artwork si trasformano secondo il desiderio in camini, lavabi, cache-pot, fonti d'illuminazione, purificatori d'aria. La nuova linea prende forma dall'innovazione applicata alla passione e alla competenza, svincolata da concetti di stile predeterminati, nel segno della più assoluta libertà. Artwork Italian Heritage è una collezione nata per dare vita a idee nuove e originali dove il gusto della scoperta resta un piacere unico e ineguagliabile.

Artwork Italian Heritage is a new concept that combines the boldest design with the maximum creative and functional versatility. The collection of ceramic sculptures born from the experience of Kerasan, leader in the production of furnishing ceramics for over sixty years, presents art objects capable of preserving maximum functionality to enrich the pleasure of living. This is how unprecedented forms are born, capable of boldly breaking every pre-established pattern and bringing the language of sculpture into interior design for every room of the house. Artwork ceramics can be transformed according to your desire into design fireplaces, washbasins, cachepots, light sources and air purifiers. The new line takes shape from innovation applied to passion and competence free from predetermined style concepts, in the name of the most absolute freedom. Artwork Italian Heritage is a collection created to give life to new and original ideas where the discovery of originality remains a unique and unparalleled pleasure.



“IMAGINATION IS MORE IMPORTANT THAN KNOWLEDGE. FOR KNOWLEDGE IS LIMITED, WHEREAS IMAGINATION EMBRACES THE ENTIRE WORLD, STIMULATING PROGRESS, GIVING BIRTH TO EVOLUTION.”

ALBERT EINSTEIN

Artwork significa forme inedite, e il desiderio di portare il linguaggio della scultura nell'interior design ed in ogni contesto abitativo sia esso una casa, un hotel o uno spazio commerciale. Artwork è anche espressione distintiva di oggetti che si collocano in spazi esterni e diventano testimoni di un nuovo concetto di arredo urbano. Le creazioni della collezione Artwork sono un inno all'originalità, e rappresentano il perfetto mix tra funzionalità, estetica ed emozione. L'artigianalità che caratterizza Artwork rende questi oggetti unici, mai uguali, portatori di dettagli che diventano valori senza tempo. Contract, spazi per eventi, yacht, uffici, aree pubbliche: le creazioni Artwork possono impreziosire ogni ambiente con una funzionalità nuova, arricchita dal linguaggio della scultura. La ceramica, reinterpretata in questa chiave, esce dagli schemi prestabiliti per estendersi in maniera efficace a ogni ambiente della casa.

Artwork means new forms, and the desire to bring the language of sculpture into interior design and into any living environment, be it a home, a hotel, or a business facility. Artwork is also a distinctive expression of objects that can be placed outside and which become witnesses of a new concept of urban design. The creations of the Artwork collection are a hymn to originality, and represent the perfect mix of functionality, aesthetics, and emotion. The craftsmanship that characterizes the Artwork collection makes these objects unique, bearers of detail that becomes a timeless value. Turnkey projects, event venues, yachts, offices, public areas: Artwork creations can furnish any environment with a new functionality, enriched by the language of sculpture. The ceramic breaks the mold and becomes suitable for any room in the house when reinterpreted in this new key.

ARTWORK ITALIAN HERITAGE A STORY OF TRUE ITALIAN PASSION

Il vero lusso è avere una scultura unica e inimitabile: per questo ogni nostra realizzazione può essere personalizzata in un'ampia gamma di finiture. Forme curiose e originali o imponenti e scenografiche sono destinate a creare effetti visivi di grande impatto, per esperienze abitative indimenticabili. Yacht, hall di esclusive strutture ricettive, lussuose ville: dove l'obiettivo è incantare e stupire, gli elementi della collezione Artwork lasceranno il segno.

True luxury means having a unique and inimitable sculpture: therefore, each of our creations can be extensively customised in a wide range of different finishes. Bizarre and original or impressive and spectacular forms are destined to create visual effects of great impact, for unforgettable living experiences. Yachts, halls of exclusive accommodation facilities, luxurious villas: the elements of the Artwork collection will leave their mark if the goal is to enchant and amaze.

MOLOCO
PAG. 06



ADAM
PAG. 10



BARREL
PAG. 14



GROOVE
PAG. 18



SEGNI
DELLE CARTE
PAG. 22



1960
PAG. 26



PEDONE
PAG. 36



MOSCARDINO
PAG. 40



COW
PAG. 44



MOLOCO: A TIMELESS FACE

DESIGN: FABRIZIO BATONI

Un componente d'arredo che presenta una spiccata multifunzionalità: una scultura, un lavabo, un camino, una lampada. MOLOCO è tutto quello che la fantasia consente d'inventare.

An interior design item that has a marked multifunctionality: it can be used as a sculpture, a sink, a heater, or a lamp. MOLOCO is whatever your imagination desires to create.



Disponibile come:

- Lavabo "freestanding" con scarico a terra o a parete. Si può abbinare a qualsiasi elemento di rubinetteria, per dare vita ad un elemento di design unico.
- Lampada d'arredo. Viene fornito con un kit luce ed una parrucca artistica. L'abbinamento tra il colore e la tipologia di lampada con le tonalità della parrucca consente di creare un punto luce unico nel suo genere. La parrucca è disponibile nei colori bianco e argento. La lampada viene accesa tramite interruttore a pedale.
- Stufa a bioetanolo. L'utilizzo di uno specifico kit, consente di utilizzare il Moloco come elemento riscaldatore per ambienti unici e di livello.
- Scultura. Può essere utilizzato come puro elemento decorativo o come cache-pot per una composizione floreale o artistica.

It can be:

- A freestanding washbasin with floor or wall outlet. It can be combined with any taps and fittings, to create a unique design element.
- A lamp. It is supplied with lighting accessories and a design lampshade that recalls a curly wig. The combination of the colour and the type of lamp, together with the shades of the cover that looks like a wig, allow you to create a unique light source. The lampshade is available in white and silver. The lamp lights up with a foot pedal switch.
- A bioethanol heating stove. The use of a specific kit allows you to use Moloco as a heater for unique and high-design environments.
- A sculpture. It can be used as a pure decorative element or as a cachepot for floral arrangements or artistic creations.





E' offerto in 18 finiture, di cui 7 "luxury", queste ultime ottenute grazie a un quadruplo processo di cottura mediante il quale è possibile fissare sulla base in ceramica la polvere d'oro o d'argento. L'artigianalità mediante la quale queste finiture sono ottenute, fa sì che ogni elemento prodotto sia unico nel suo genere.

It is available in 18 colours, 7 of which are called "luxury" because they are obtained by a quadruple firing process through which gold or silver dust can be applied and imprinted on the ceramics. The craftsmanship by which these finishes are achieved means that each product is unique.



ADAM: A BREATH OF FRESH AIR FOR YOUR HOME

DESIGN: FABRIZIO BATONI



ADAM è una scultura in ceramica e un elemento iconico della collezione Artwork. Una scultura che diventa contemporaneamente un riscaldatore e purificatore d'aria. Grazie a un sistema che integra una lampada UV e due resistenze elettriche, la funzionalità di ADAM regala il piacere di avere aria pulita e riscaldata". ADAM può essere controllato da remoto tramite app e si integra perfettamente nei sistemi di domotica (gestiti tramite Alexa, Google Home, Siri,...).

ADAM is a ceramic sculpture and an iconic element of the Artwork collection. A sculpture that becomes a heater and an air purifier at the same time.

Thanks to a system that integrates a UV lamp and two electrical resistances, the functionality of the ADAM sculpture gives the pleasure of having both clean and heated air. ADAM can be controlled remotely via a special app and it integrates seamlessly into home automation systems (managed via Alexa, Google Home, Siri...)



ADAM è disponibile in 4 finiture, di cui oro e platino. Su richiesta, può essere personalizzato con finiture specifiche che ne esaltano l'originalità e l'unicità.

ADAM is available in 4 colours, including gold and platinum. On request, it can be customised with special colours that enhance its originality and uniqueness.

BARREL: TRANSFORMATION AND CREATIVITY

Barrel è un elemento non convenzionale e non catalogabile. Ricorda a prima vista i fusti di petrolio, ma grazie alla sua capacità di trasformare la propria destinazione d'uso, reinventa l'interior design in una prospettiva polifunzionale.

Barrel is an unconventional and unclassifiable element. At first sight it recalls an oil drum, but it is capable of reinventing interior design in a multifunctional perspective thanks to its ability to transform its intended use.

E' disponibile come:

- Lavabo "freestanding" con scarico a terra o a parete. Si può abbinare a qualsiasi elemento di rubinetteria, e grazie alle infinite personalizzazioni, diventa un elemento di design unico.
- Lampada d'arredo. Viene fornito con un kit luce ed una fiamma artistica, disponibile in 3 tonalità (oro, argento e verde). La lampada viene accesa tramite interruttore a pedale con cavo di collegamento a presa 220 V.
- Stufa a bioetanolo. L'utilizzo di uno specifico kit, ne esalta la personalità come elemento riscaldatore per interni ed esterni.
- Decorazione pura o cache-pot per inventarsi qualsiasi soluzione artistica e di design.

Barrel can be:

- A freestanding washbasin with floor or wall outlet. It can be combined with any taps and fittings thus becoming a unique design element thanks also to the infinite possibilities of customisation.
- A lamp. Supplied with lighting accessories and a design lampshade that recalls a burning flame, and available in 3 colours (gold, silver and green). The lamp lights up when you press the foot pedal switch after connecting the cable to a 220V socket.
- A bioethanol heating stove. The use of a specific kit enhances the features of the Barrel as a heating element for indoors and outdoors.
- A simple decoration or cachepot that offers many artistic furnishing solutions.



E' disponibile complessivamente in 16 finiture, che comprendono tonalità lucide e satinare, metalliche per originali risultati effetto specchio e 4 colori pregiati quali oro, oro rosso, argento e platino. Su richiesta, può essere personalizzato e diventare un elemento d'arredo senza eguali. Tutte le finiture sono applicate con processi manuali che esaltano l'artigianalità e lo stile italiano.

It is available in a total of 16 colours, including glossy, matte, and metallic shades for original and impressive mirror-like visual effects plus 4 precious colours: gold, red gold, silver, and platinum. It can be customised on request thus becoming a unique interior design item. All finishes are applied with manual processes that enhance Italian craftsmanship and style.



GROOVE: BEAUTY AND ESSENTIALITY TAKE SHAPE

DESIGN: FABRIZIO BATONI



GROOVE è la scelta più elegante per un orinatoio da destinare all'arredo di spazi contract e alberghi di lusso ma anche un versatile oggetto di design che può arricchire ogni tipo di ambiente e diventare una base elegante per un'originale fioriera!

The GROOVE is the most elegant choice for a urinal to be used for furnishing spaces and luxury hotels but also a versatile design object that can enrich any type of environment and become an elegant base for an original planter.



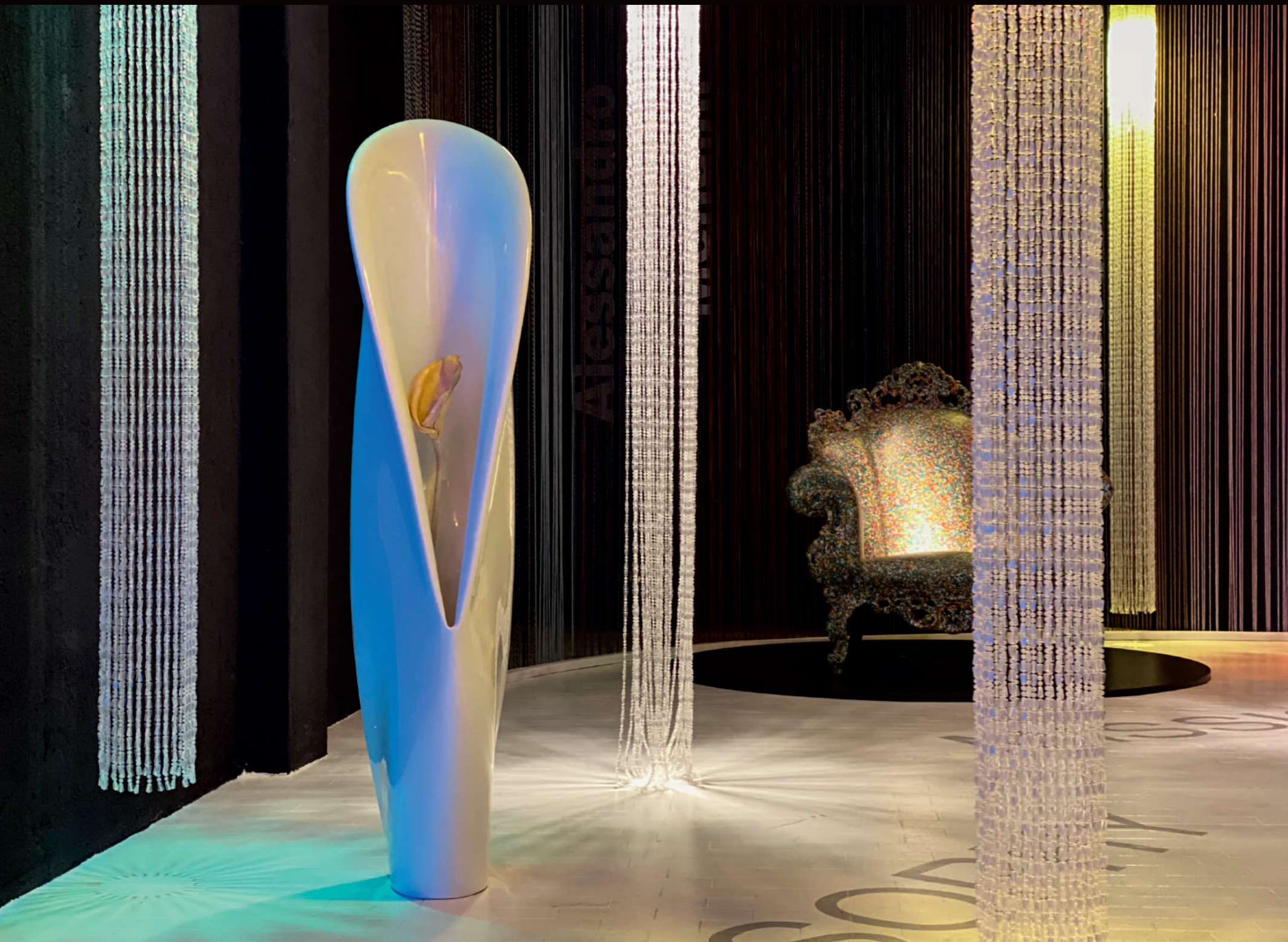

Tra rigore delle linee e morbidezza della forma non esiste alcun contrasto. Eleganza, leggerezza e ceramica diventano un'armonia unica di sensi ed emozioni. Disponibile nel colore bianco e in versione bicolore (esterno personalizzabile su richiesta e interno bianco).

There is no contrast between the rigor of the lines and the softness of the form. Elegance, lightness, and ceramic become a unique harmony of senses and emotions. Groove is available in a two-tone variation (the exterior can be customised on request whilst the interior remains white) or all white.

SEGNİ DELLE CARTE: CERAMIC PLAYS WITH TRADITIONS

DESIGN: ADRIANA LOHMANN

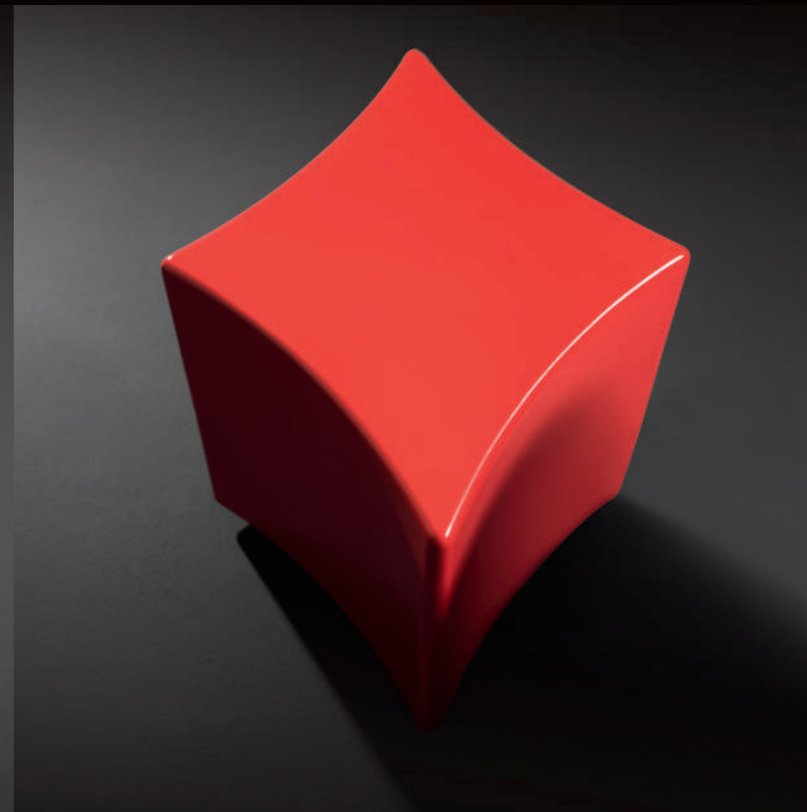
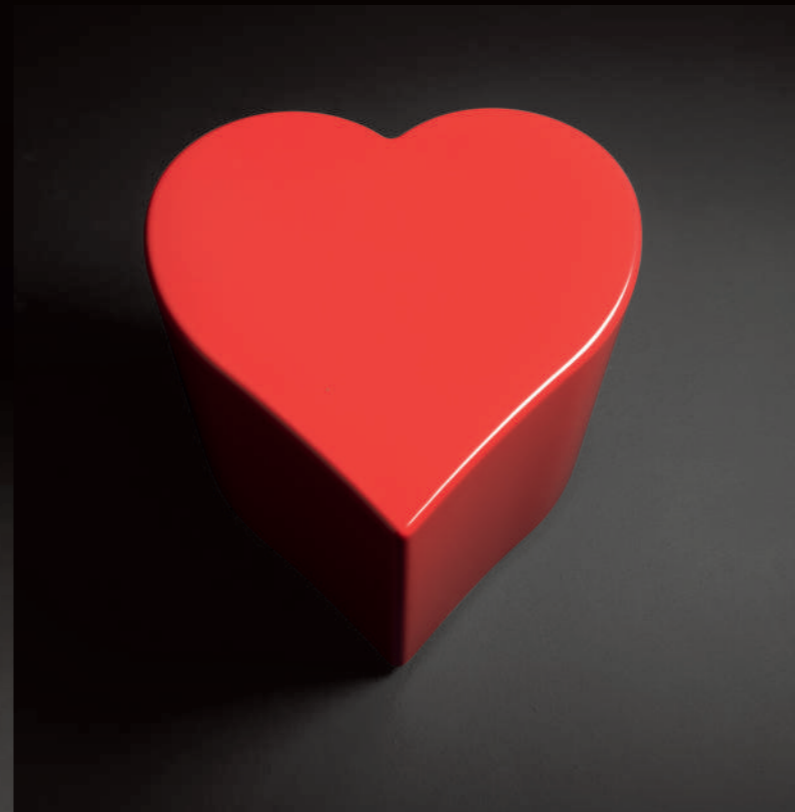

La ceramica cambia forma, colore, destinazione d'uso con la massima disinvoltura per dare vita ai più originali tavolini per il living caratterizzati dai segni delle carte francesi, tutti da collezionare.

Ceramics changes shape, colour, and intended use with the utmost ease to give life to the most original tables for a living room characterized by the suits of French cards, all collector's items.

Quattro elementi iconici utilizzabili in spazi condivisi come hall di hotel, lounge aeroportuali, o sale da gioco.

Fruibili anche come sedute e collocabili in spazi indoor piuttosto che in contesti di arredo urbano.

Disponibili nei 2 colori classici delle carte da gioco (rosso e nero), nella versione luxury, ripensata abbinando l'oro al platino e in un bianco lucido perfetto per chi vuole creare uno stile "Total White".

Four iconic elements that can be used in open spaces such as a hotel lobby, an airport lounge, or a casino.

These tables can also be used as seats and can be placed indoors or included in urban design projects.

They are available in the 2 typical colours of playing cards (red and black), in the "luxury" variation, redesigned by combining gold with platinum, and in a glossy white suitable for those who want to create a "Total White" style.



1960: IT IS THE VALUE OF DETAIL THAT MAKES THE DIFFERENCE

1960: il lavabo perfetto per un'installazione sia freestanding che a parete. Un oggetto funzionale che diventa un'opera d'arte: realizzato mediante un basamento in plexiglas a sezione rotonda o quadrata al cui interno è posizionato un lavabo circolare sormontato da un piano lavorato a mano. Ognuno di questi piani presenta un colore, una rugosità e una mazzatura particolari, tali da donare a ogni elemento un attestato di originalità e unicità. All'interno della base in plexiglas sono presenti dei led che garantiscono un effetto di luce "diffusa".

The 1960 is the perfect washbasin prepared for both freestanding and wall installation.

A functional object that becomes a work of art: it is composed of a round or square-shaped Plexiglas framework and a bowl-shaped ceramic washbasin which is positioned on the top with a hand-made flat surface all around.

Each of these tops has an attractive colour, but also a special rough texture or marbling so as to give each element great originality and uniqueness. Inside the Plexiglas framework there are LED lights that ensure the effect of "diffused" light.

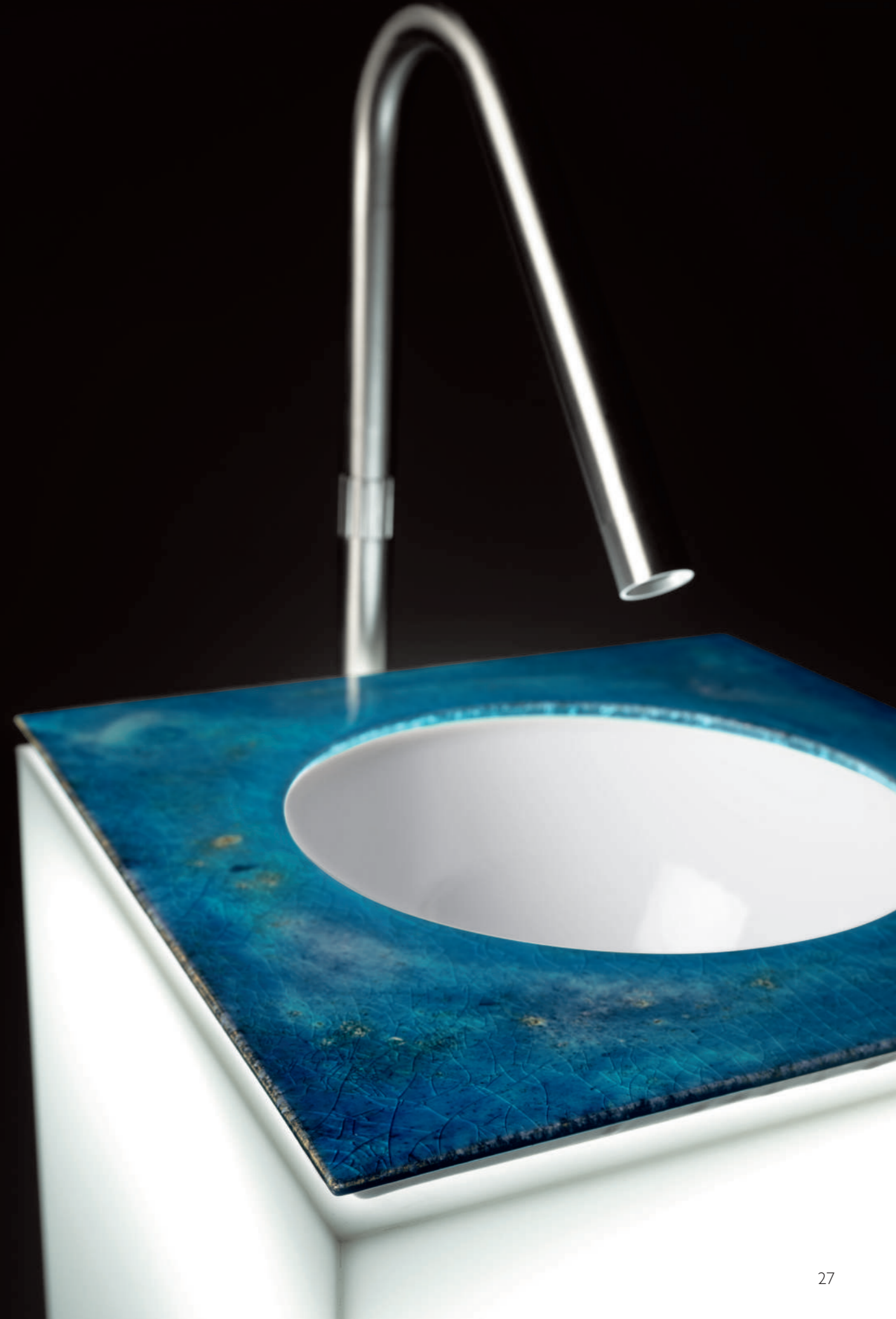

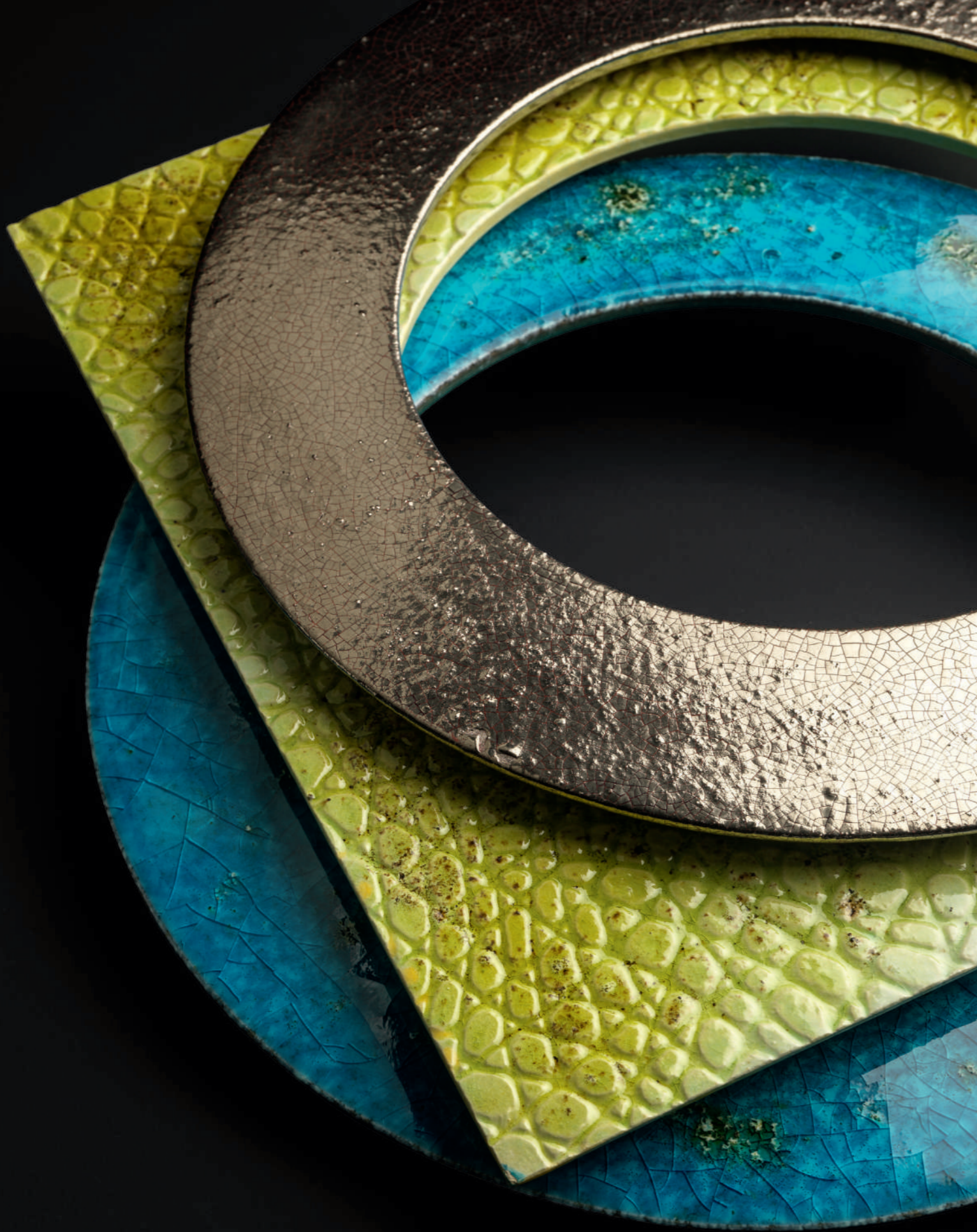



1960 può essere abbinato a qualsiasi elemento di rubinetteria, che può essere anch'esso a terra o a parete. La collezione 1960 è disponibile anche senza base in plexiglas. Il lavabo e il piano superiore possono essere posizionati su una mensola a parete per creare un ambiente unico come forma e finiture.

1960 can be combined with any kind of tap, whose installation can be floor or wall mounted. The 1960 collection is also available without the Plexiglas framework. The washbasin with its top can be placed on a wall shelf to create a unique environment in terms of style and finishes.



1960 è disponibile in 12 finiture a base rotonda e 12 finiture a base quadrata e 3 differenti rugosità superficiali (liscio, elefante e cocco).

The item 1960 is available in 12 colours for both shapes and 3 different finishes for the surrounding top: smooth or textured to resemble elephant or crocodile skin.

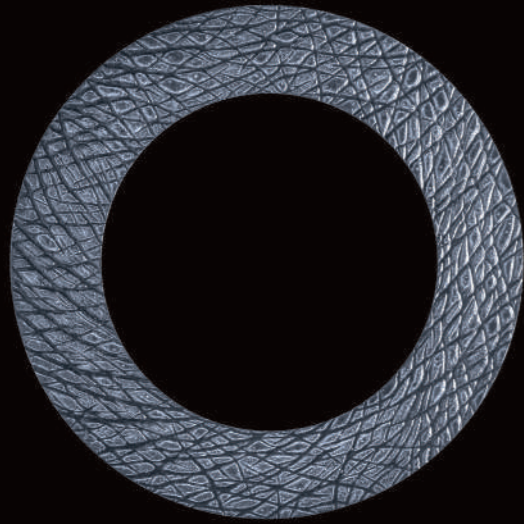

ELEFANTE METALLO

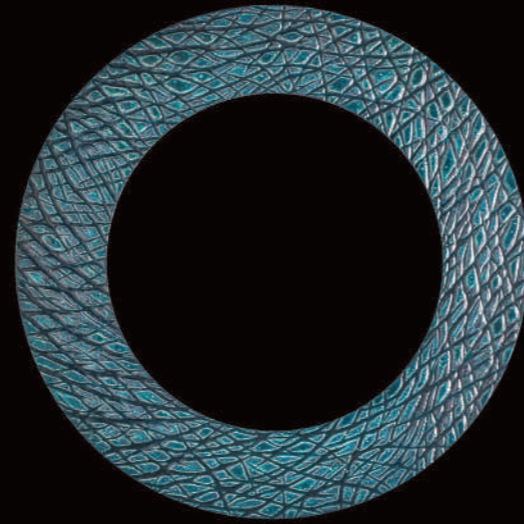

ELEFANTE VERDE

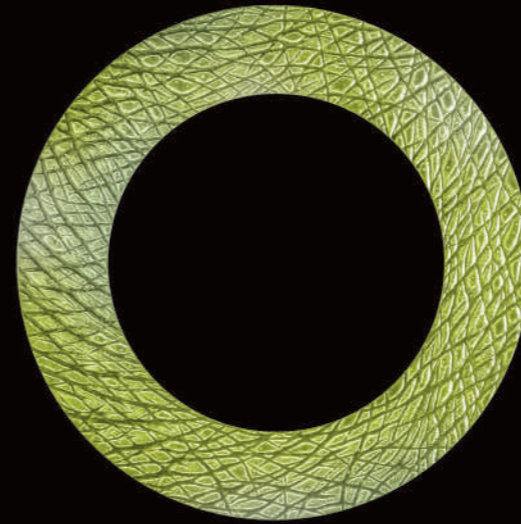

ELEFANTE GIALLO

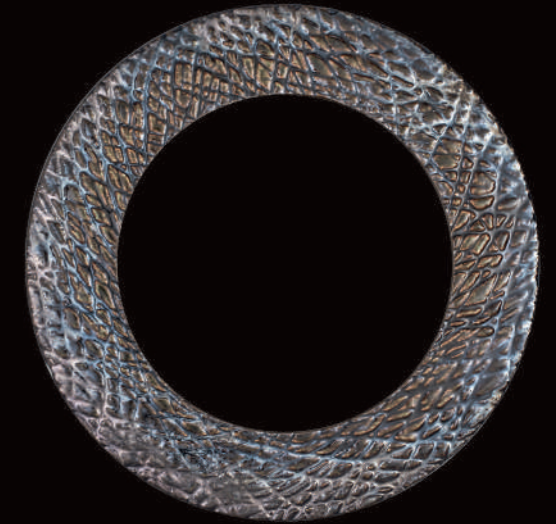

ELEFANTE MARRONE

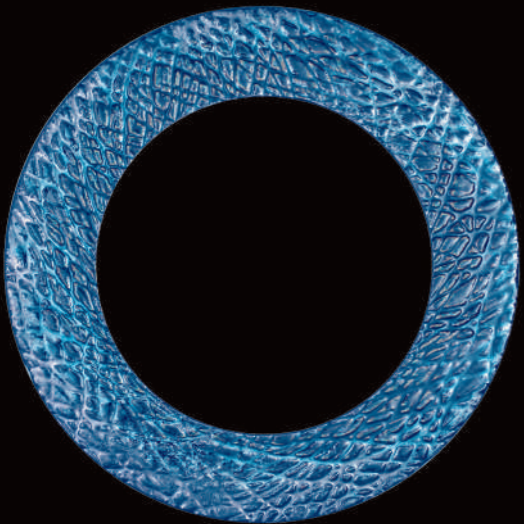

ELEFANTE AZZURRO

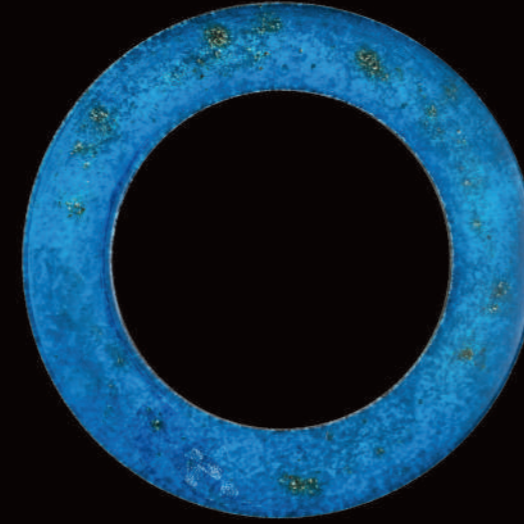

TONDO AZZURRO SFUMATO

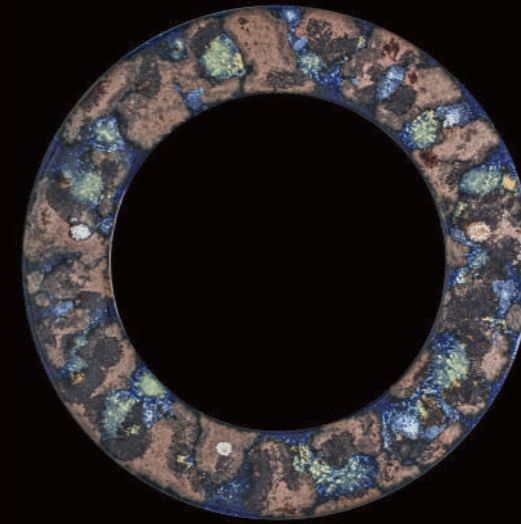

TONDO GALASSIA AZZURRA

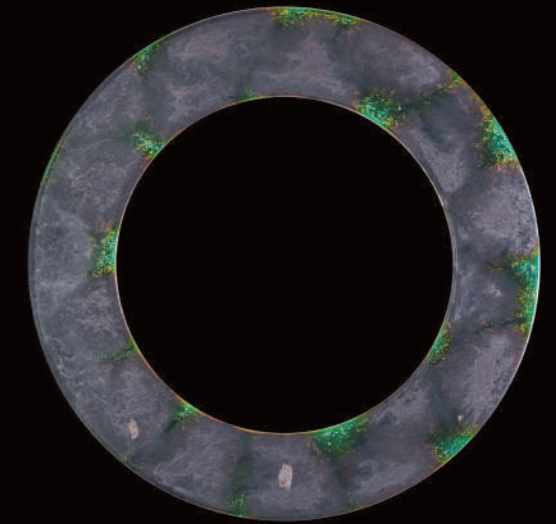

TONDO GALASSIA VERDE

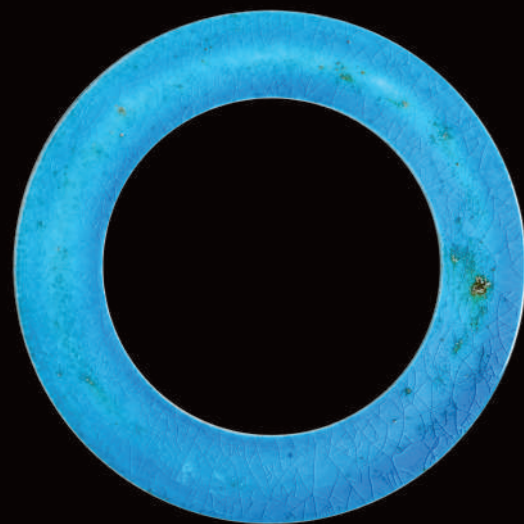

TONDO CELESTE



TONDO PLATINO SU ROSSO



TONDO ORO SU BLU

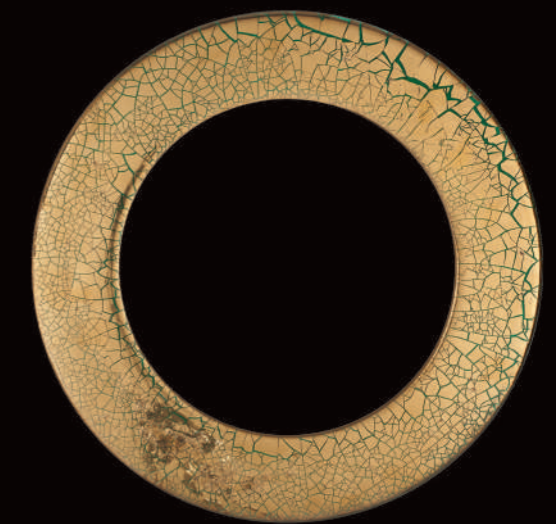

TONDO ORO SU VERDE CHIARO

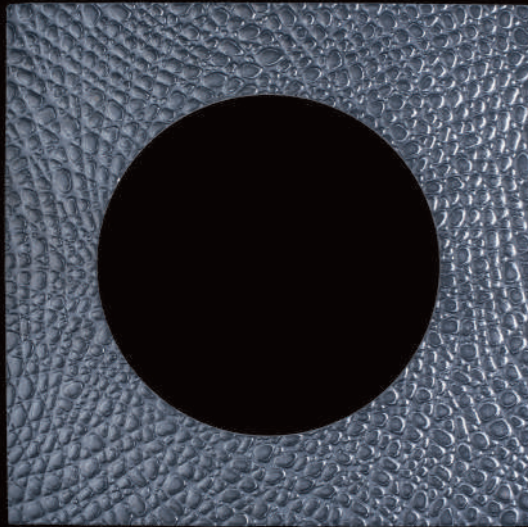

COCCO METALLO

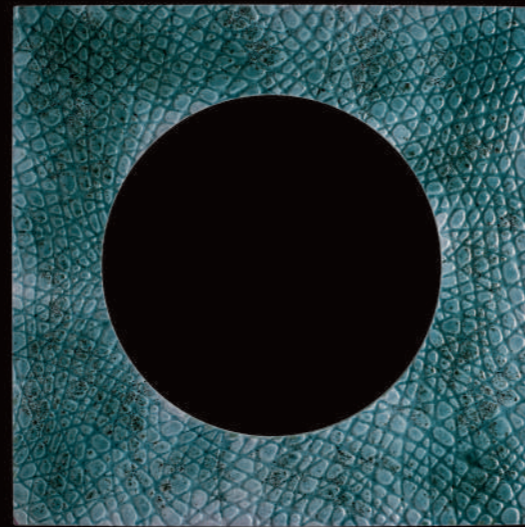

COCCO VERDE

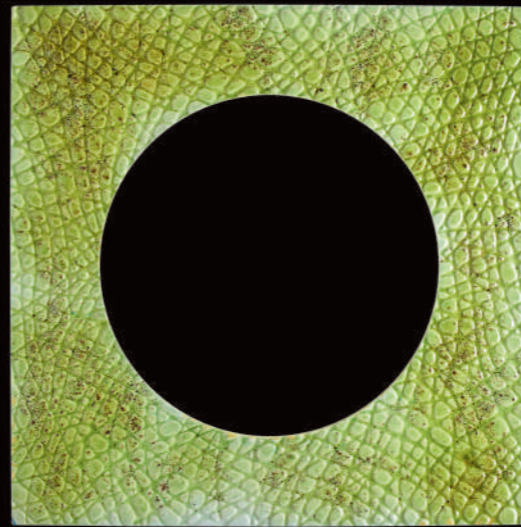

COCCO GIALLO

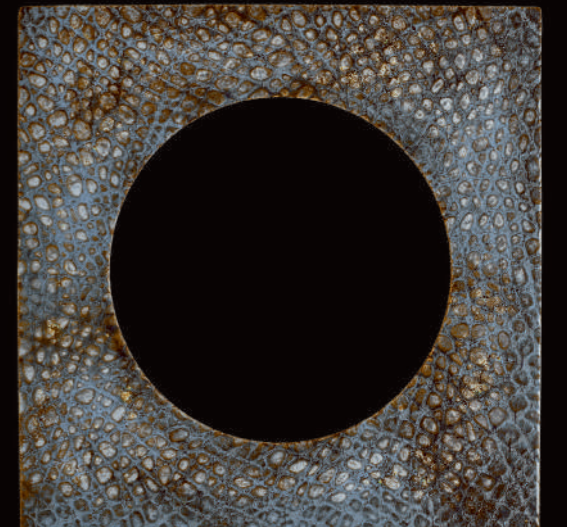

COCCO MARRONE

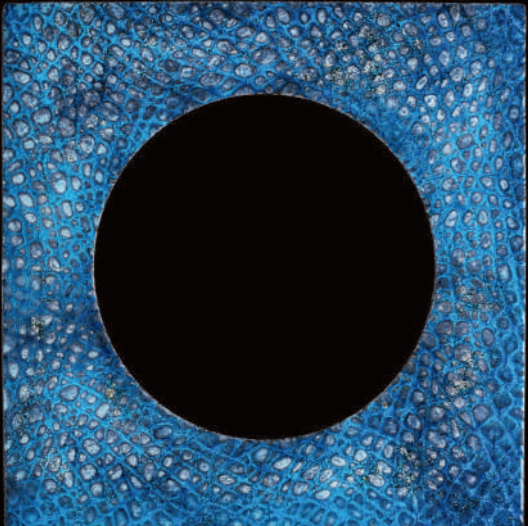

COCCO AZZURRO

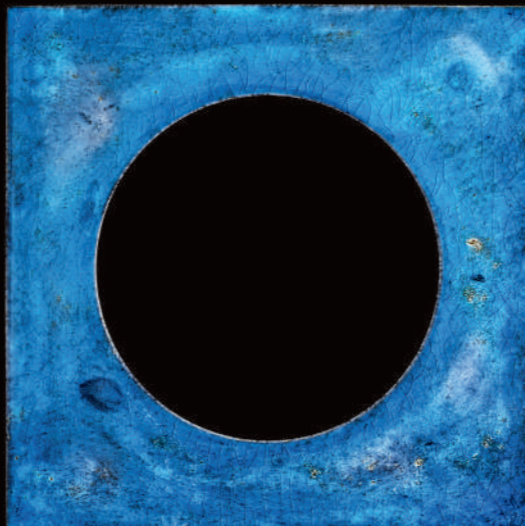

QUADRO AZZURRO SFUMATO

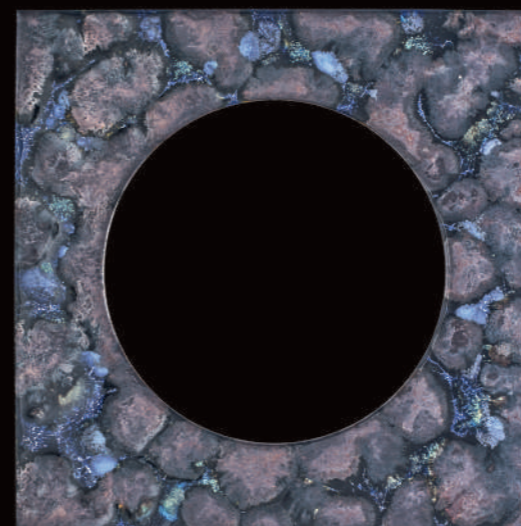

QUADRO GALASSIA AZZURRA

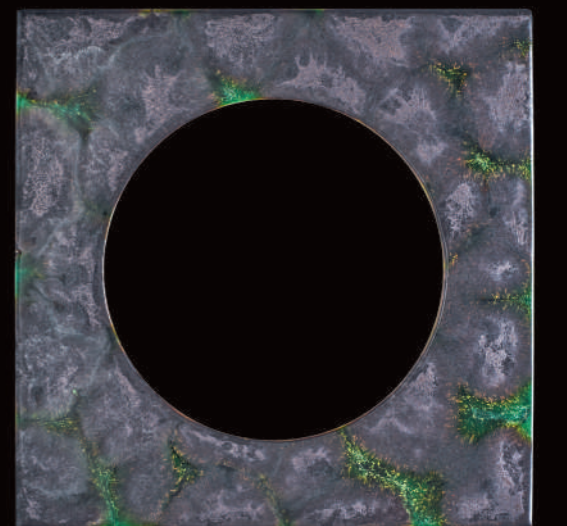

QUADRO GALASSIA VERDE

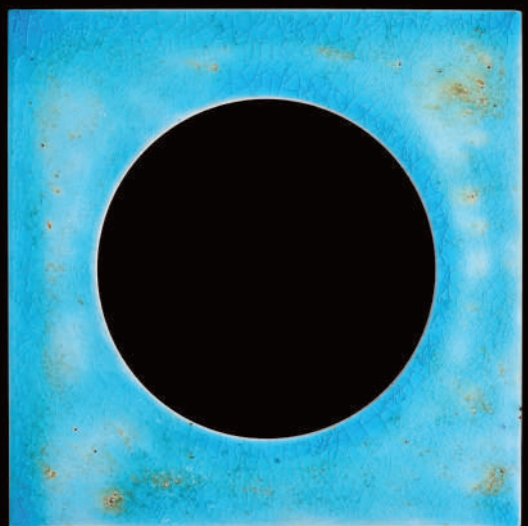

QUADRO CELESTE

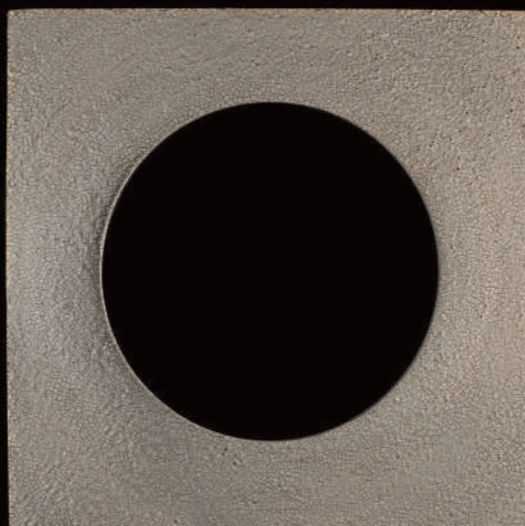

QUADRO PLATINO SU ROSSO

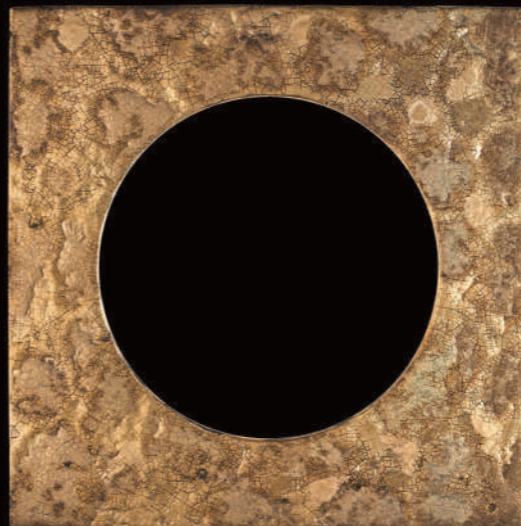

QUADRO ORO SU BLU

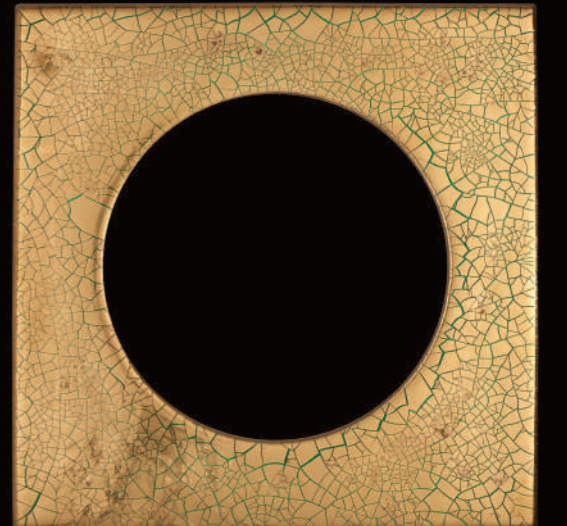

QUADRO ORO SU VERDE CHIARO

PEDONE: ELEGANCE IS CHECKMATE

DESIGN: ADRIANA LOHMANN

Un'originale scultura in ceramica e simbolo del gioco più antico del mondo. Un elemento che irradia luce, estro e personalità all'interno di ogni ambiente e che rappresenta la scelta d'arredo più innovativa per la tua casa o per un ambiente "contract".

An original ceramic sculpture, symbol of the oldest game in the world. A product that radiates light, flair, and personality in any environment and that represents the most innovative choice of furniture for your home or for a contract environment.





Fruibile come puro elemento decorativo o come "punto luce", quest'ultimo disponibile con cavo di alimentazione a presa 220 V e interruttore di accensione a pedale o con batteria ricaricabile. Offerto in 4 finiture standard, oro e platino. Nella versione "punto luce" la sfera superiore è disponibile in 4 tonalità: bianco lucido, bianco matt, marmorizzato bianco e marmorizzato nero.

Usable as a pure decorative element or as a lamp, available with power cable for 220V socket and a foot switch or with rechargeable battery. It is available in 4 standard colours, gold and platinum. In the "light source" variation, the globe-shaped scone is available in 4 colours: glossy white, matt white, marbled white and marbled black.



MOSCARDINO: NEW OBJECTS, NEW WORLDS, AND NEW INSPIRATIONS.

DESIGN: FABRIZIO BATONI

Decidi tu come lo vedi. All'interno di un negozio o in una camera d'hotel, MOSCARDINO rappresenta la seduta più originale per incuriosire, divertire, affascinare. Disponibile nei colori classici bianco e nero, e in altre 8 tonalità adatte a soddisfare ogni proposta di arredamento.

Up to you how to see it: inside a shop or in a hotel room, the MOSCARDINO represents the most original seat to intrigue, entertain or fascinate. MOSCARDINO is available in the traditional colours of black and white, and 8 additional shades suitable to satisfy any furnishing project.



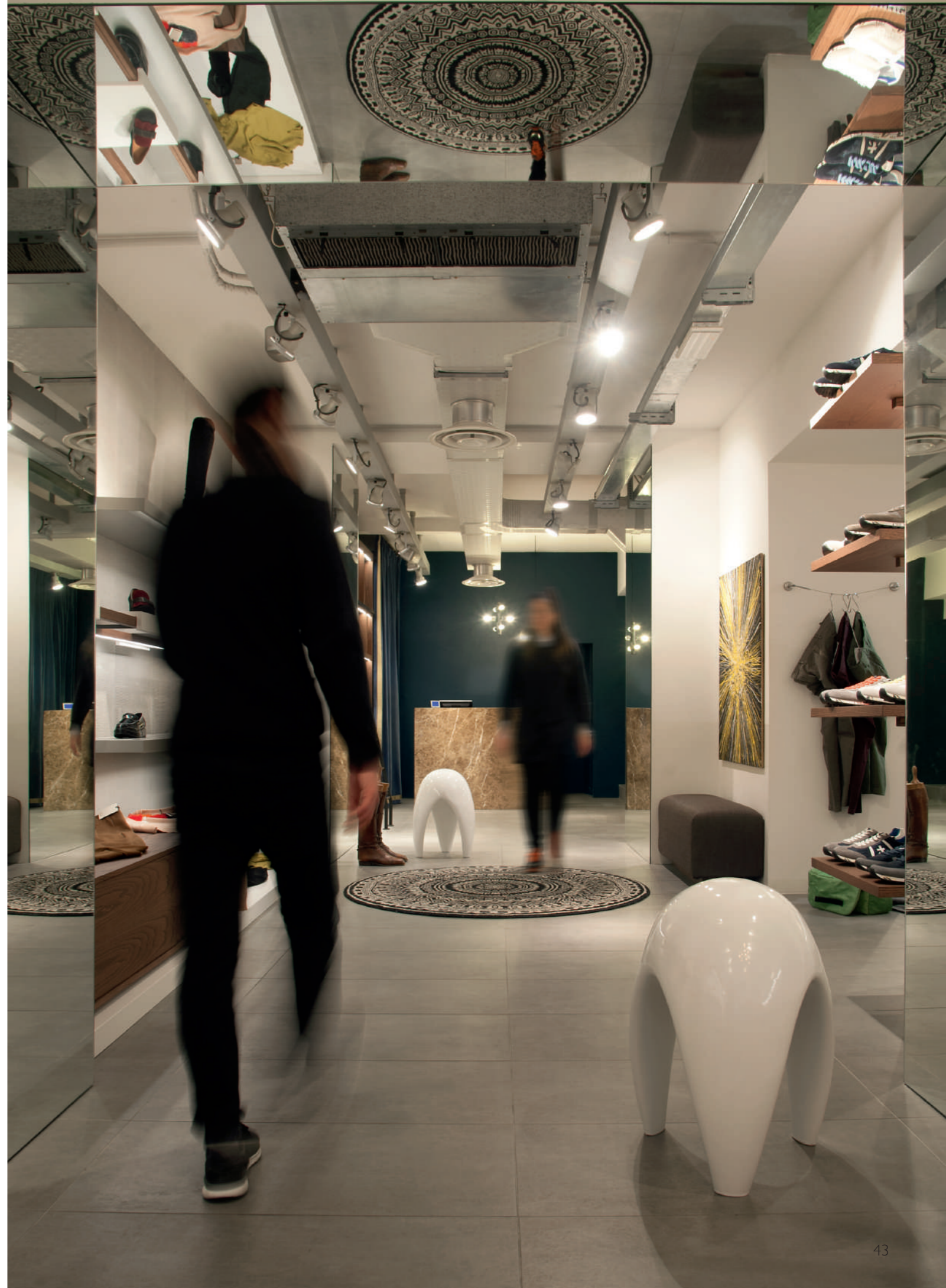

DESIGN: FABRIZIO BATONI

COW: CREATIVITY AND DESIGN FIND THEIR IDEAL PLACE

Si scrive COW, si legge libertà assoluta: lo sgabello in ceramica più sorprendente è la scelta ideale per creare un ambiente da ricordare. Lo spazio ideale dove design, dinamismo ed unicità si accomodano nel modo più elegante.

Disponibile in 12 tonalità sia lucide che opache.

You write COW, but you read absolute freedom: this amazing ceramic stool is the ideal choice to create a memorable environment. The ideal space where design, dynamism and uniqueness come together in a most elegant way.

Available in 12 colours, both glossy and matte.



4740 MOLOCO
 Lavabo freestanding
 scarico a parete o pavimento
 Peso 43,00 kg

Freestanding washbasin
 wall outlet or floor
 Weight 43,00 kg

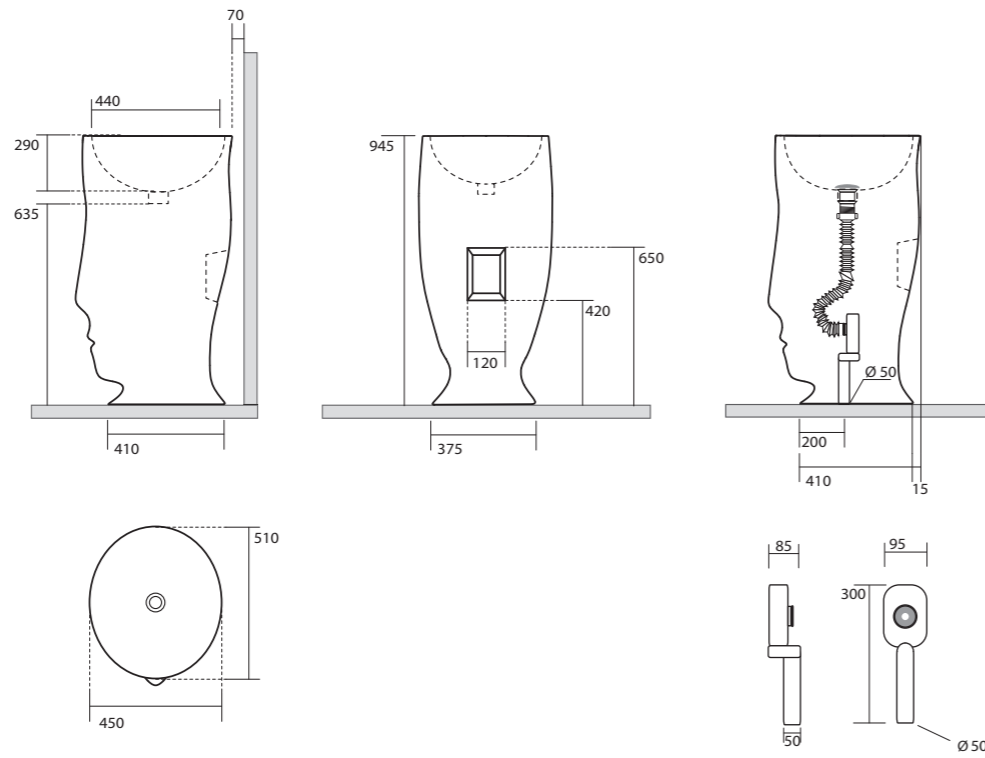

7568K2
 Kit stufa bioetanolo per Moloco
 Peso 10,00 kg

Moloco bio-stove kit
 Weight 10,00 kg

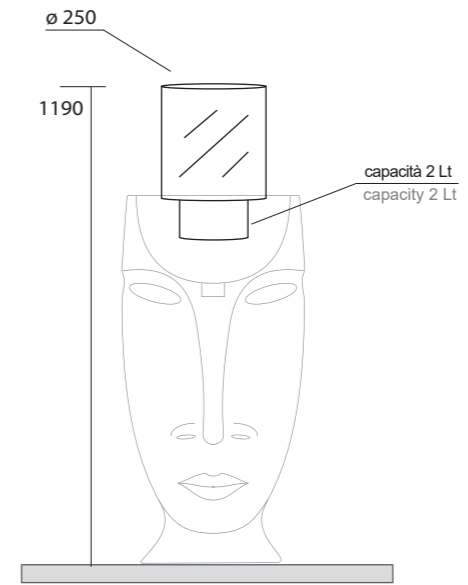

Cestello acciaio inox
 Stainless steel basket

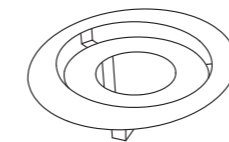

Serbatoio bioetanolo
 Bioethanol tank



Vetro borosilicato
 Borosilicate glass

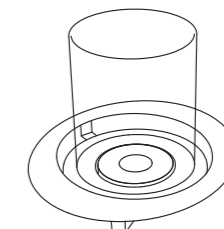
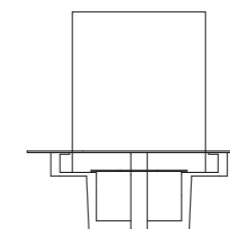
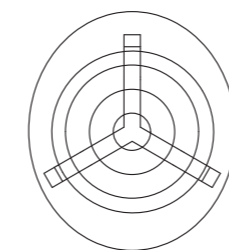
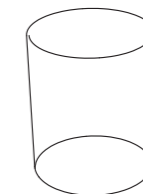

4720 ADAM
 Scultura
 Peso 51,00 kg

Sculpture
 Weight 51,00 kg

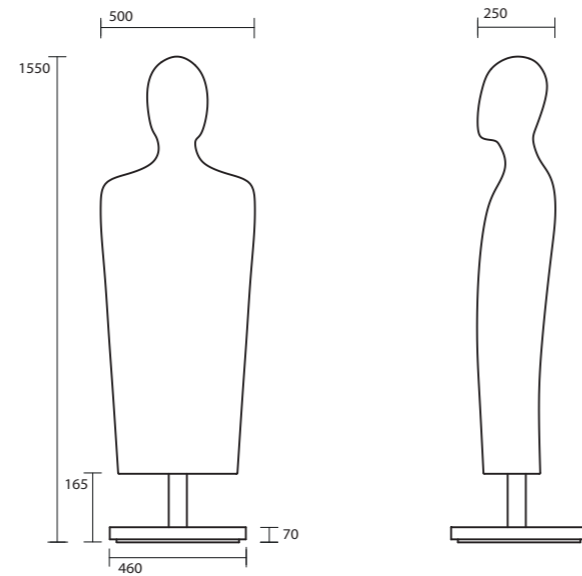

4721 ADAM
 Scultura termoventilatore e
 purificatore aria
 Peso 58,00 kg

Sculpture fan heater
 and air purifier
 Weight 58,00 kg

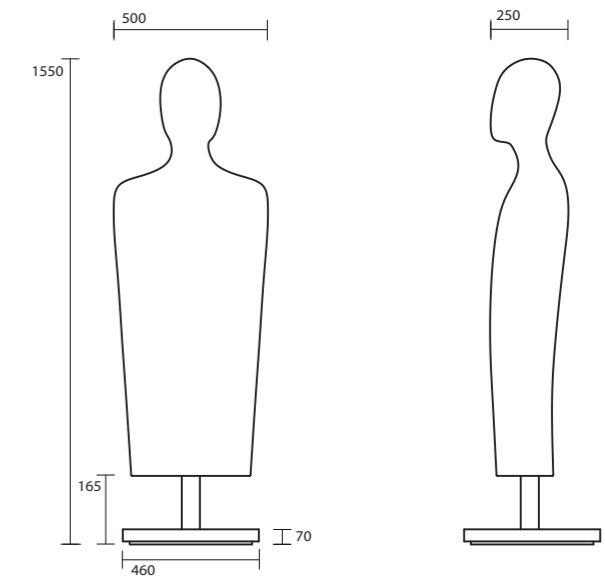

ADAM – CARATTERISTICHE TECNICHE

Tensione di alimentazione: 230V (ac).
 Corrente massima: 4A.
 Flusso aria: 100 m3/h.
 Lampada germicida UV-C 9W Philips, vita utile 9000 ore con decadimento delle prestazioni del 20%.
 Potenza di riscaldamento: 750W con regolazione della potenza in due steps, 350W+350W.
 Presenza di due capsule termiche di protezione con temperatura massima 55°C.
 Comando manuale e wireless interfacciabile con Alexa, Google Home, Siri.
 Tramite l'App "Smart Life" sarà possibile configurare* le tre accensioni: ventilazione con lampada germicida, primo riscaldatore 350W, secondo riscaldatore 350W.

*Le istruzioni per la configurazione delle tre accensioni sono fornite insieme al kit di acquisto di Adam.

ADAM – TECHNICAL SPECIFICATIONS

Supply Voltage: 230 V (ac).
 Maximum current: 4A
 Air flow: 100 m3/h.
 Germicidal lamp UV-C 9W Philips, service life 9000 hours with 20% of performance drop.
 Heating power: 750W with power adjustment in 2 steps, 350W+350W.
 Two thermal protecting capsules with maximum temperature of 55°C.
 Manual control and wireless that can be interfaced with Alexa, Google Home, Siri.
 With the App "Smart Life" it is possible to set up* three switching: air ventilation with germicidal lamp, first 350W heater, second 350W heater.

*Instructions to set up the three switching are provided with the Adam purchase kit.

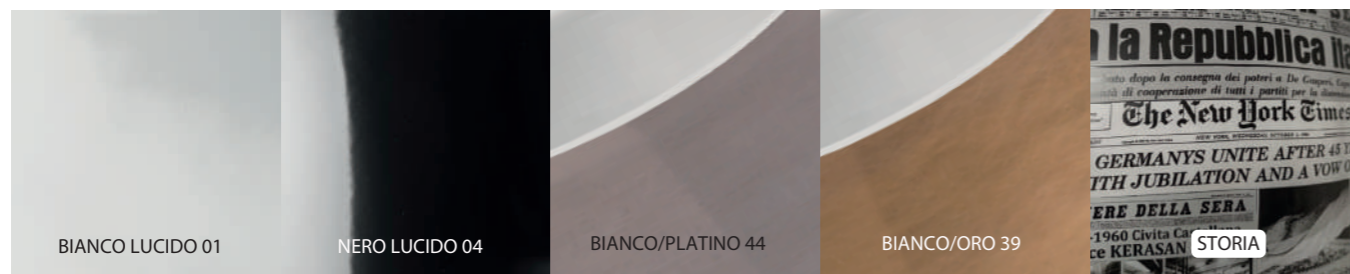

- PERSONALIZZAZIONI SU RICHIESTA
- CUSTOMISED FINISHINGS ON DEMAND

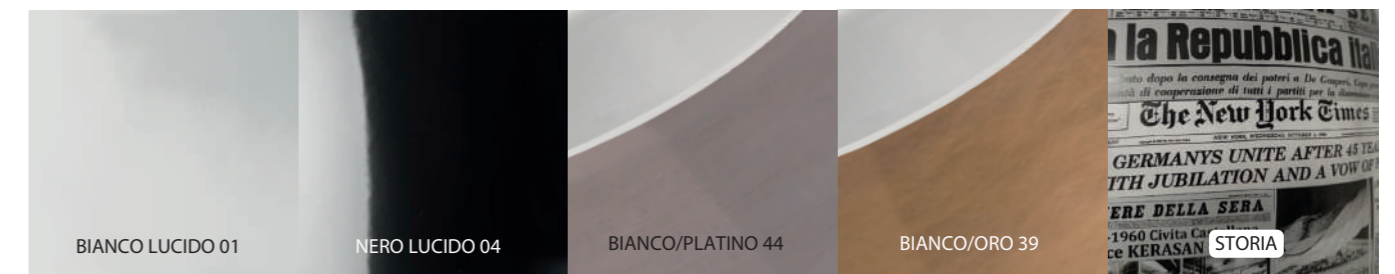

- PERSONALIZZAZIONI SU RICHIESTA
- CUSTOMISED FINISHINGS ON DEMAND

4742 BARREL
 Lavabo freestanding
 scarico suolo completo
 di sifone e tubo
 flessibile di scarico
 Peso 43,00 kg

Freestanding washbasin
 floor outlet siphon and
 flexible waste pipe included
 Weight 43,00 kg

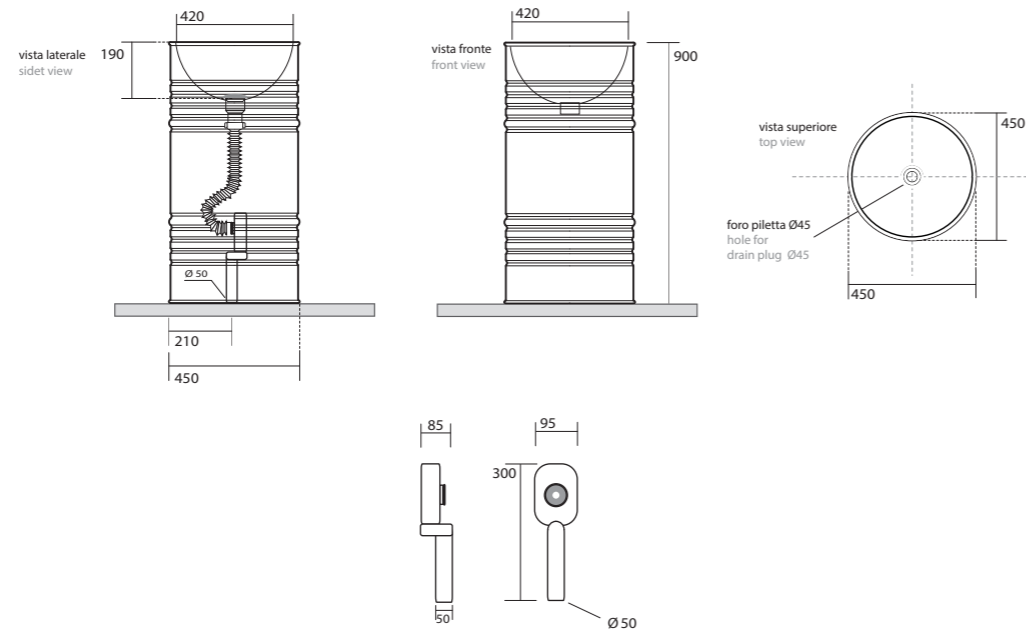

4743 BARREL
 Lavabo freestanding
 scarico parete
 Peso 43,00 kg

Freestanding washbasin
 wall outlet
 Weight 43,00 kg

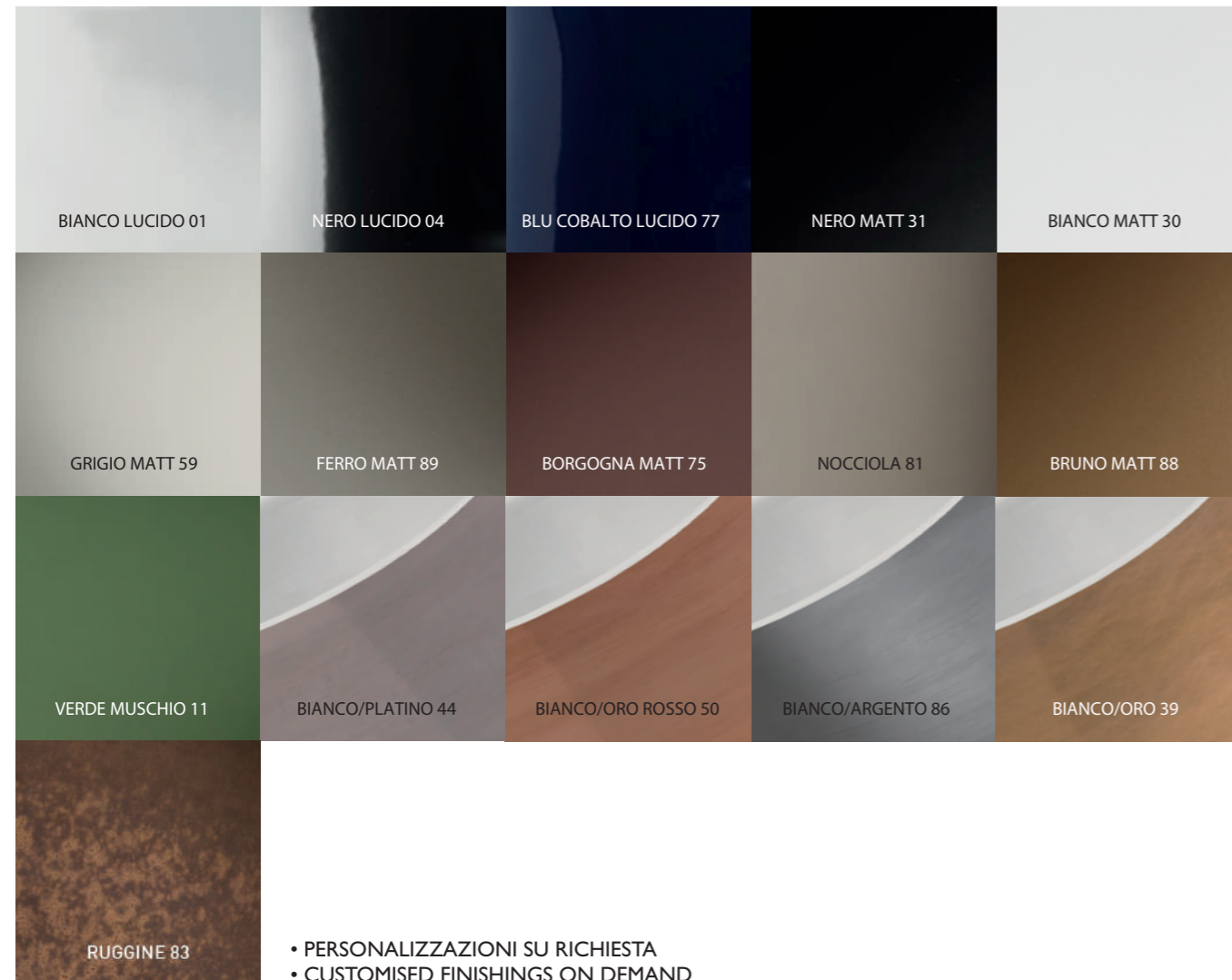
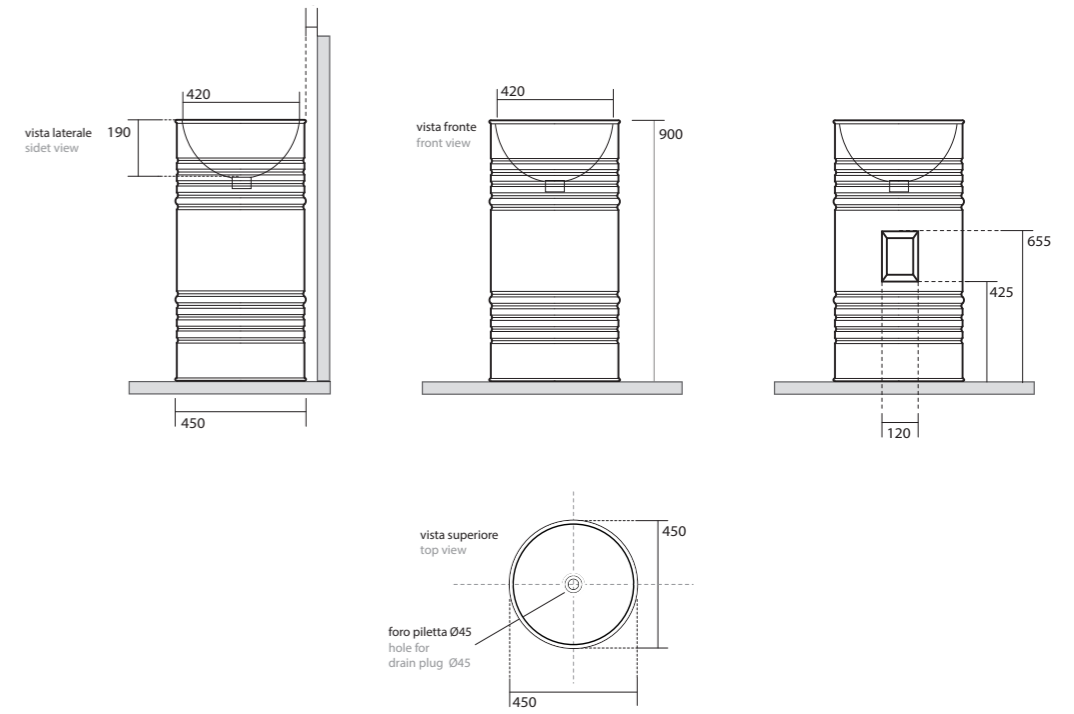

7568K I
 Kit stufa bioetanolo per Barrel
 Peso 10,00 kg

Barrel bio-stove kit
 Weight 10,00 kg

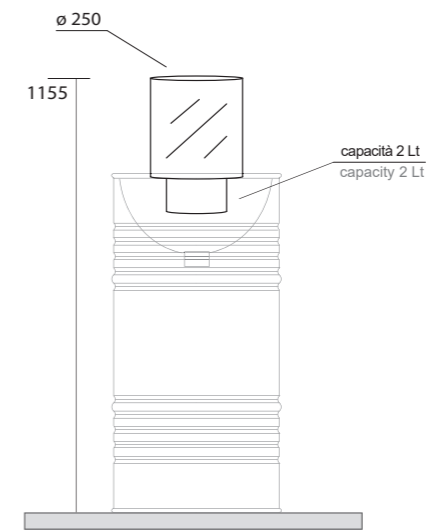

Cestello acciaio inox
 Stainless steel basket

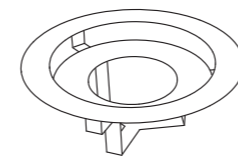

Serbatoio bioetanolo
 Bioethanol tank

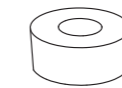

Vetro borosilicato
 Borosilicate glass

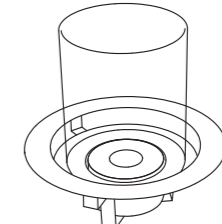
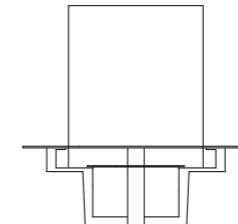
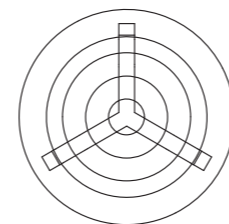
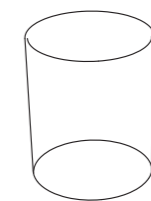

4714 CUORE
Tavolo con base in acciaio
Peso 33,00 kg

Table with steel base
Weight 33,00 kg

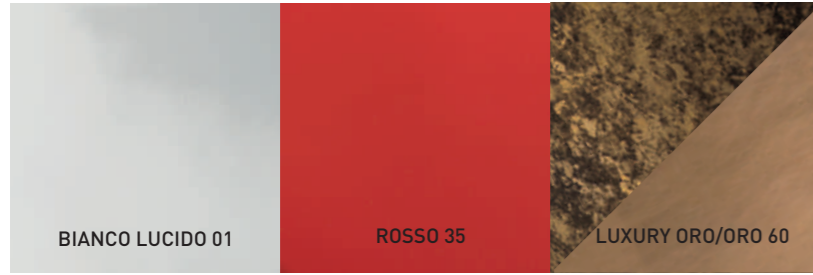
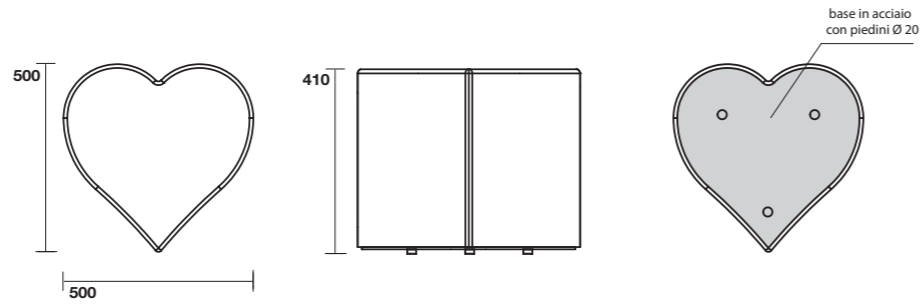

4716 FIORI
Tavolo con base in acciaio
Peso 30,00 kg

Table with steel base
Weight 30,00 kg

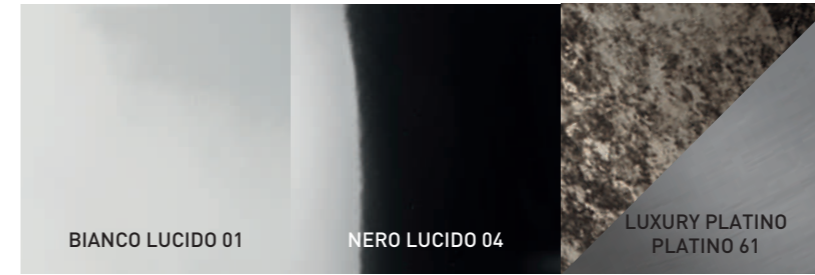
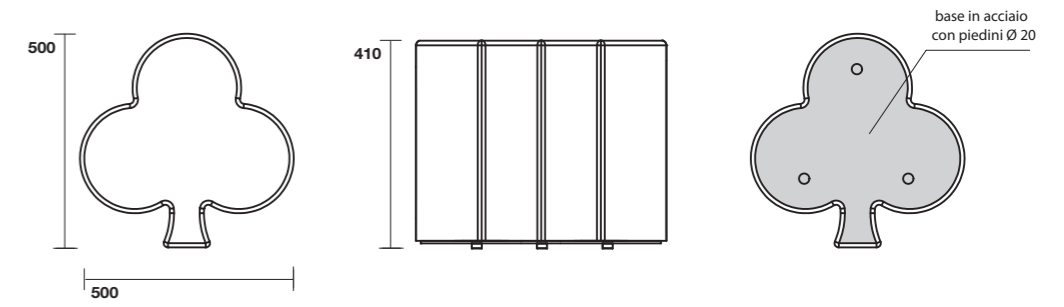

4715 QUADRI
Tavolo con base in acciaio
Peso 24,00 kg

Table with steel base
Weight 24,00 kg

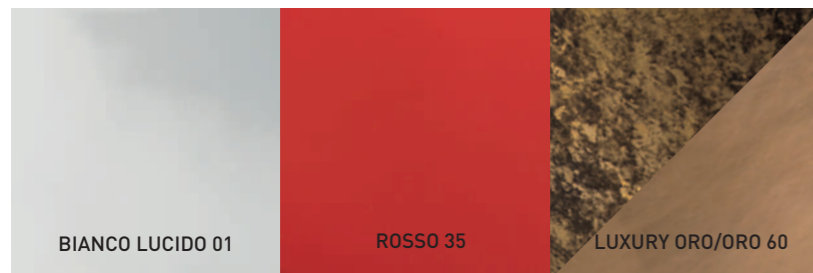
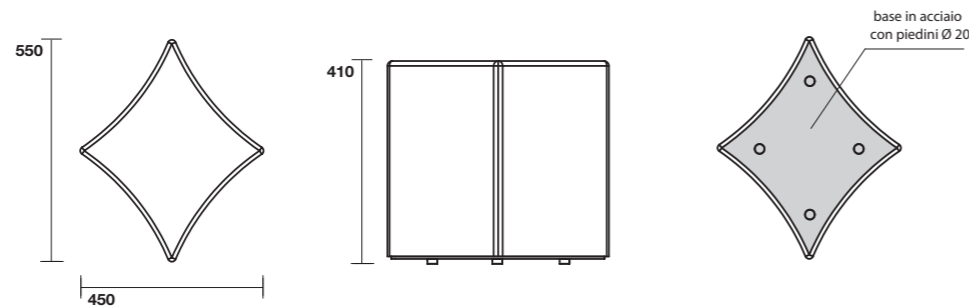

4717 PICCHE
Tavolo con base in acciaio
Peso 29,00 kg

Table with steel base
Weight 29,00 kg

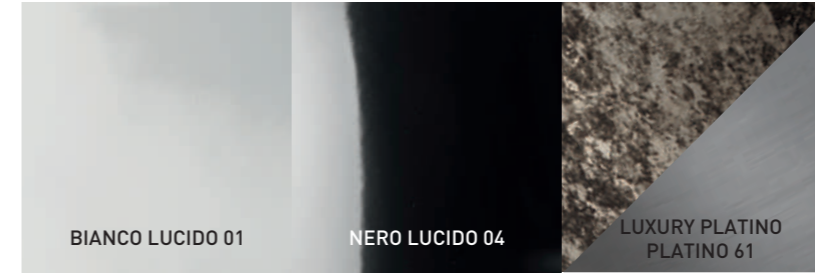
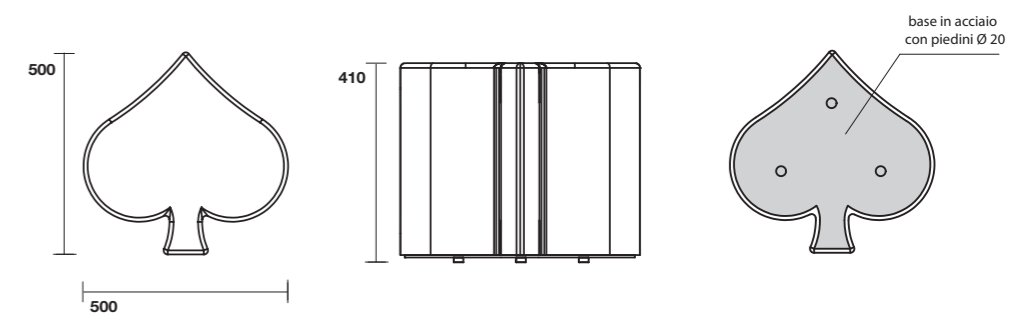

4750 Lavabo 1960
Washbasin

7581K1 struttura quadrata in plexiglas bianco opale con illuminazione led e sifone per scarico a terra

7581K1 square opal white floor-outlet plexiglas framework with led light and bottle trap

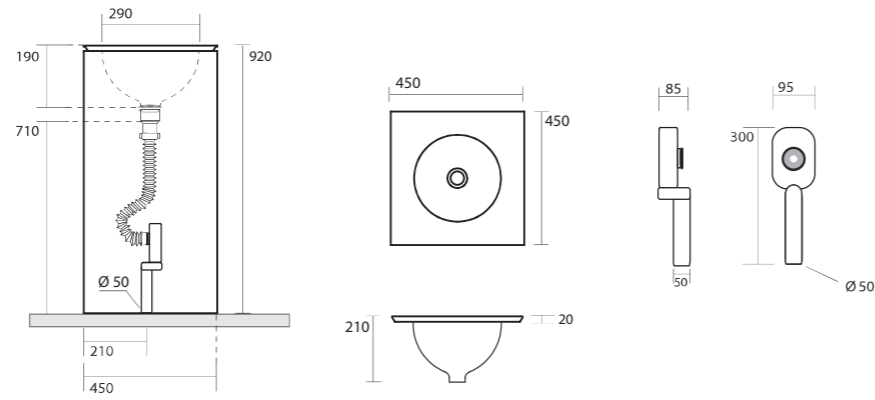

4750 Lavabo 1960
Washbasin

757613 struttura quadrata in plexiglas bianco opale con illuminazione led e sifone per scarico a parete

757613 square opal white floor-outlet plexiglas framework with led light

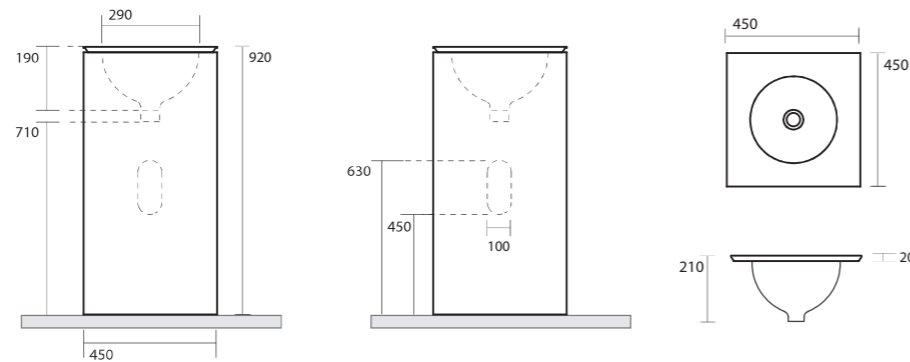

4751 Lavabo 1960
Washbasin

7580K1 struttura tonda in plexiglas bianco opale con illuminazione led e sifone per scarico a terra

7580K1 round opal white floor-outlet plexiglas framework with led light and bottle trap

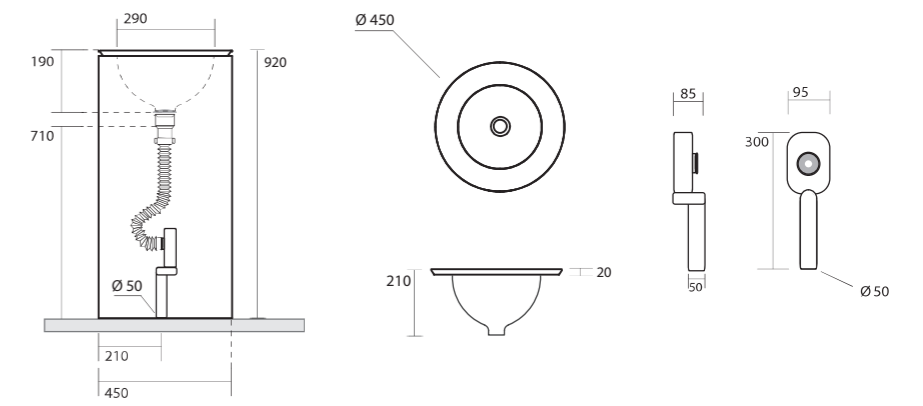

4751 Lavabo 1960
Washbasin

757612 struttura tonda in plexiglas bianco opale con illuminazione led e sifone per scarico a parete

757612 round opal white floor-outlet plexiglas framework with led light

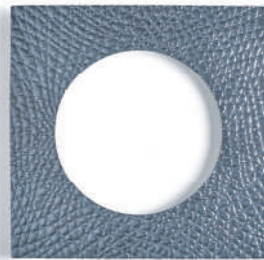
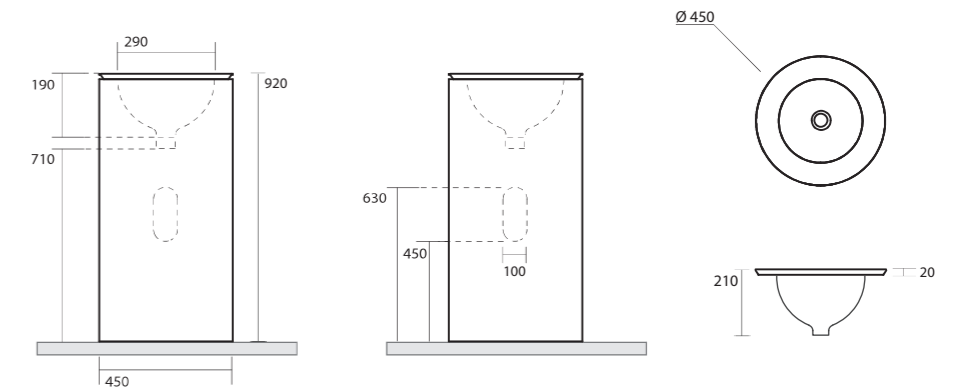

COCCO METALLO

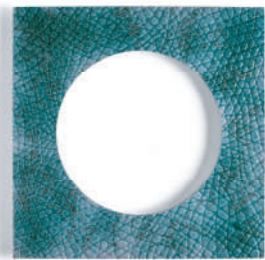

COCCOVERDE

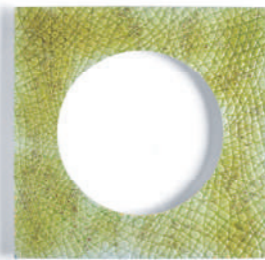

COCCO GIALLO

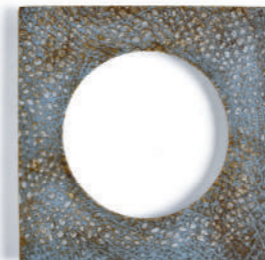

COCCO MARRONE



COCCO AZZURRO



QUADRO AZZURRO SFUMATO

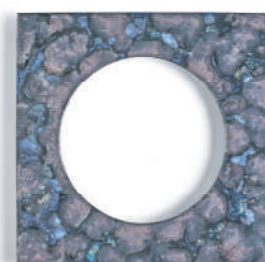

QUADRO GALASSIA AZZURRA

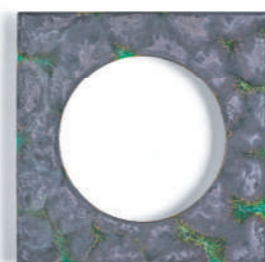

QUADRO GALASSIA VERDE



QUADRO CELESTE



QUADRO PLATINO SU ROSSO



QUADRO ORO SU BLU



QUADRO ORO SUVERDE CHIARO

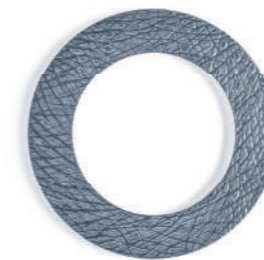

ELEFANTE METALLO



ELEFANTE VERDE



ELEFANTE GIALLO

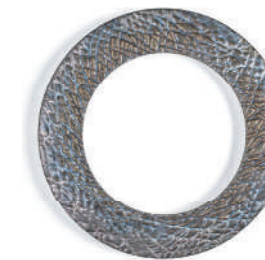

ELEFANTE MARRONE



ELEFANTE AZZURRO



TONDO AZZURRO SFUMATO



TONDO GALASSIA AZZURRA

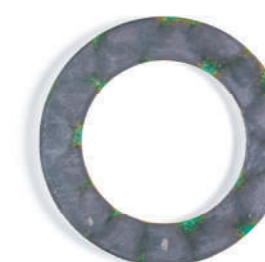

TONDO GALASSIA VERDE



TONDO CELESTE



TONDO PLATINO SU ROSSO



TONDO ORO SU BLU



TONDO ORO SUVERDE CHIARO

4712 PEDONE
 Scultura
 Peso 26,00 kg

Sculpture
 Weight 26,00 kg

4713 PEDONE
 Lampada
 Peso 23,00 kg

Lamp
 Weight 23,00 kg

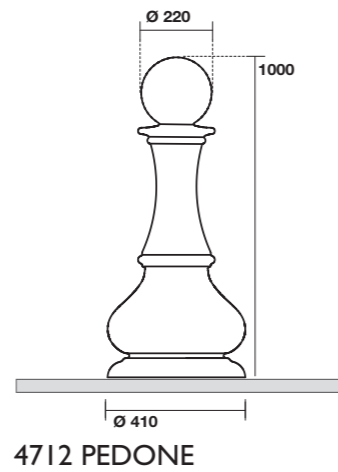

4712 PEDONE

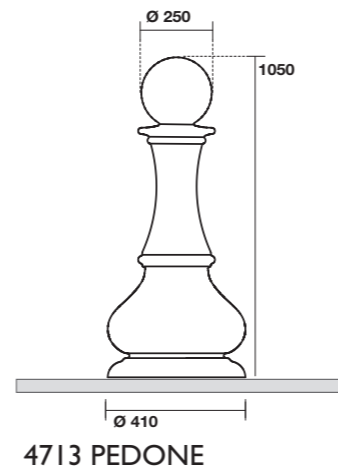

4713 PEDONE

Disponibile in due versioni:

1) Con cavo di alimentazione: AC 220 V.

Accensione / spegnimento mediante interruttore a pedale.

Lampade a led con potenza compresa tra i 15-25 W e attacco E27.

2) Con batteria a Ioni di Litio ricaricabile.

Tempo di ricarica: circa 10 ore .

Tempo di funzionamento: circa 8 ore.

Potenza: 3W.

Led: 28 (R/G/B/W) .

Alimentazione: AC 100-240V 50-60 Hz.

Telecomando per accensione / spegnimento e cambio colore / intensità luce.

Caricare completamente il kit LED almeno una volta al mese per garantirne l'efficienza.

Available in two versions:

1) Via power cable: AC 220 V.

Power on/off via foot switch.

LED lamp with suggested power range: 15-25 W.

Standard E27 lamp bases.

2) Lithium ions rechargeable battery.

Charging time: approx. 10 hours.

Life time: approx. 8 hours .

Power: 3W.

Led: 28 (R/G/B/W) .

Power supply: AC 100-240V 50-60 Hz.

Remote control to power on/off and change color / light intensity .

Fully recharge the LED kit at least once a month to ensure optimal efficiency.

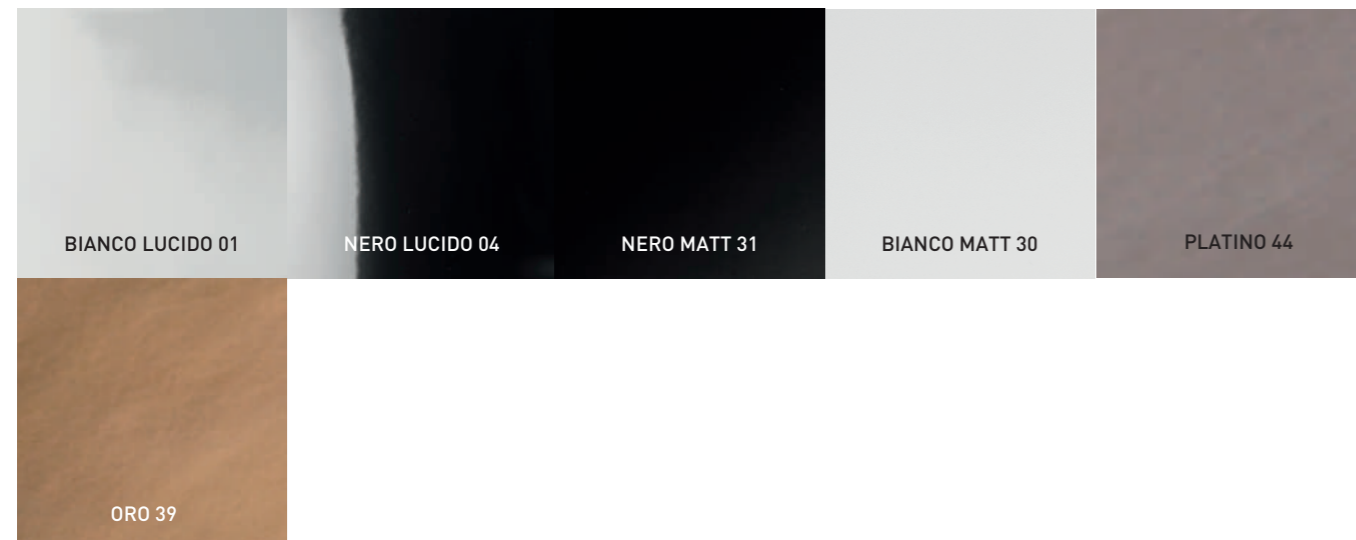

4730 GROOVE
 Orinatoio completo di fissaggio
 e sifone
 Peso 29,00 kg

Urinal fixings screws and siphon
 included
 Weight 29,00 kg

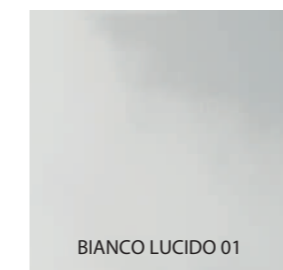
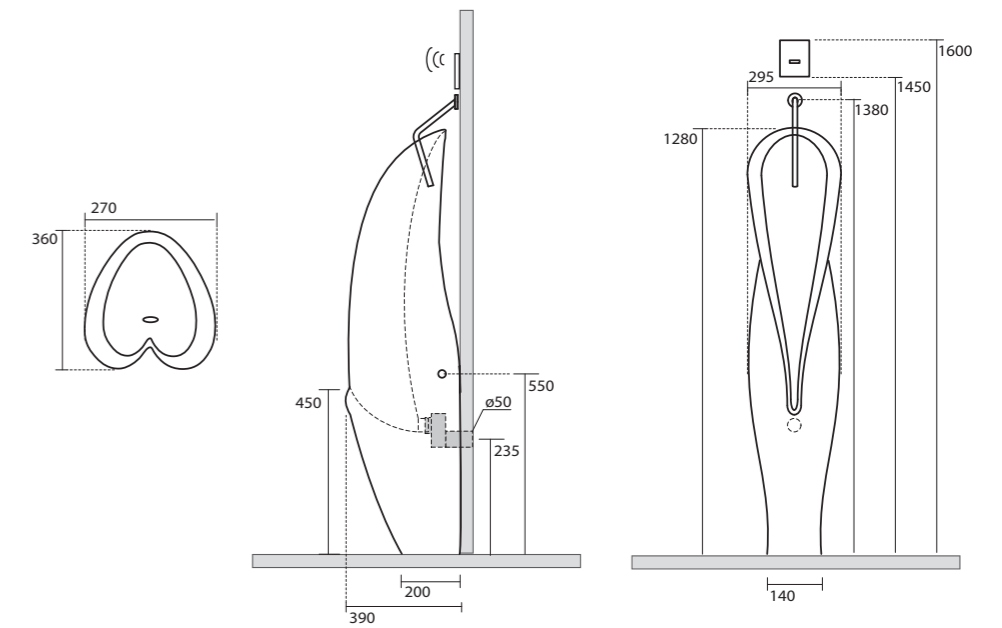

• PERSONALIZZAZIONI SU RICHIESTA
 • CUSTOMISED FINISHINGS ON DEMAND

4702 MOSCARDINO

Sgabello
Peso 17,00 kg

Stool
Weight 17,00 kg

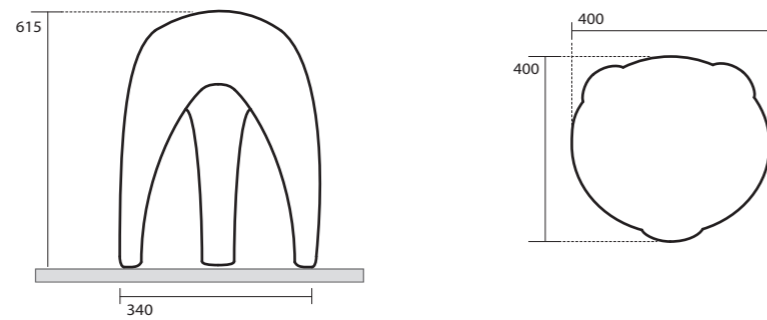

4701 COW

Sgabello
completo di base in acciaio
Peso 20,00 kg

Stool complete with steel base
Weight 20,00 kg

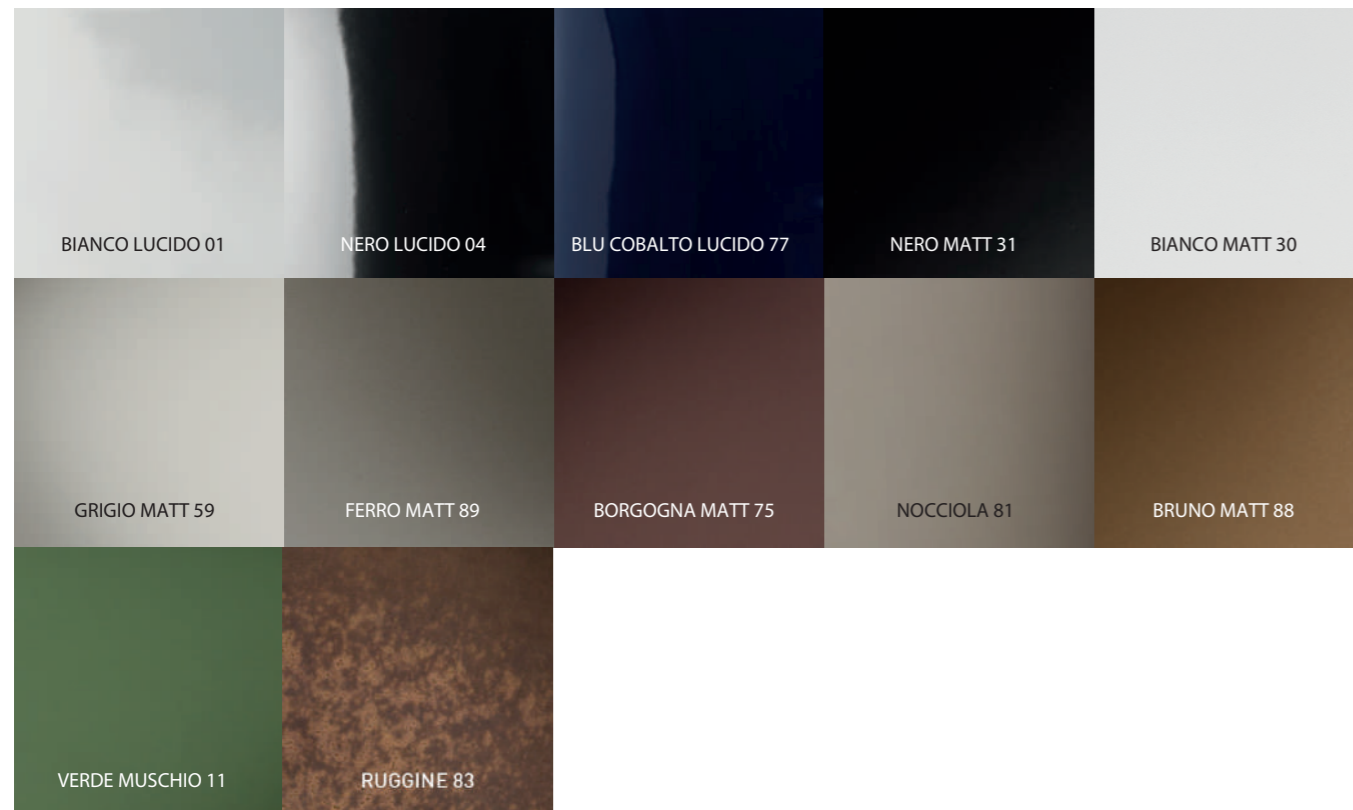
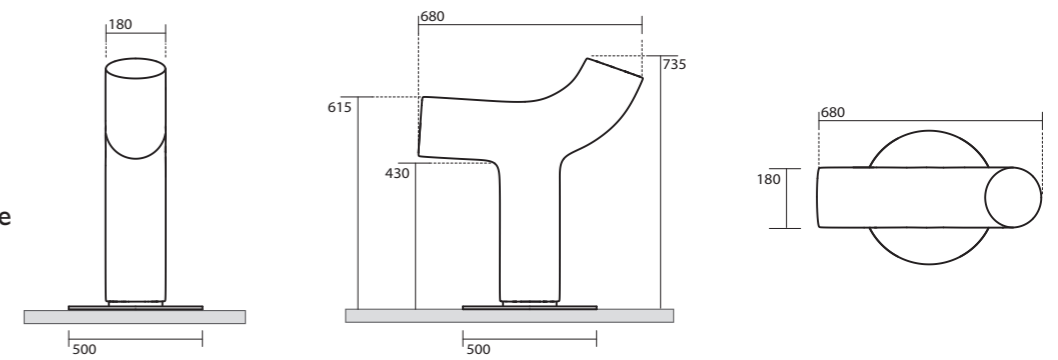

| | BIANCO 01 | BIANCO MATT 30 | NERO LUCIDO 04 | NERO MATT 31 | ROSSO 35 | LUXURY ORO 60 | LUXURY ORO ROSSO 03 | LUXURY PLATINO 61 | GRIGIO MATT 59 | BORGOGNA MATT 75 |
|------------|-----------|----------------|----------------|--------------|----------|---------------|---------------------|-------------------|----------------|------------------|
| MOLOCO | ● | ● | ● | ● | | ● | ● | ● | ● | ● |
| ADAM | ● | | ● | | | | | | | |
| BARREL | ● | ● | ● | ● | | | | | ● | ● |
| GROOVE | ● | | | | | | | | | |
| CUORE | ● | | | | ● | ● | | | | |
| QUADRI | ● | | | | ● | ● | | | | |
| PICCHE | ● | | ● | | | | | ● | | |
| FIORI | ● | | ● | | | | | ● | | |
| 1960 | | | | | | | | | | |
| PEDONE | ● | ● | ● | ● | | | | | | |
| MOSCARDINO | ● | ● | ● | ● | | | | | ● | ● |
| COW | ● | ● | ● | ● | | | | | ● | ● |

| BLU COBALTO LUCIDO 77 | NOCCIOLA 81 | RUGGINE 83 | BRUNO MATT 88 | FERRO MATT 89 | VERDE MUSCHIO 11 | BIANCO ORO 39 | BIANCO PLATINO 44 | BIANCO ARGENTO 86 | BIANCO ORO ROSSO 50 | FINITURE SPECIFICHE PERSONALIZZAZIONI |
|-----------------------|-------------|------------|---------------|---------------|------------------|---------------|-------------------|-------------------|---------------------|---------------------------------------|
| ● | ● | | ● | ● | ● | ● | ● | ● | ● | |
| | | | | | | ● | ● | | | ● |
| ● | ● | ● | ● | ● | ● | ● | ● | ● | ● | ● |
| | | | | | | | | | | ● |
| | | | | | | | | | | |
| | | | | | | | | | | |
| | | | | | | | | | | |
| | | | | | | | | | | |
| | | | | | | | | | | ● |
| | | | | | | ● | ● | | | |
| ● | ● | ● | ● | ● | ● | | | | | |
| ● | ● | ● | ● | ● | ● | | | | | |

ART DIRECTION + GRAPHIC PROJECT
GEK COMUNICAZIONE

PHOTO
ROBERTO COSTANTINI

PRINT
TELLIGRAF

COPYRIGHT © 5/2021 ARTWORK ITALIAN HERITAGE

Artwork Italian Heritage by Kerasan si riserva di apportare in qualsiasi momento modifiche tecniche, costruttive e dimensionali utili al miglioramento dei propri prodotti; pesi e misure sono da considerarsi indicativi. Le tonalità dei sanitari, a causa delle peculiarità della lavorazione ceramica, sono suscettibili di lievi variazioni da considerarsi in tolleranza. Gli allestimenti fotografici sono realizzati a fini estetici e non indicano soluzioni d'installazione.

Artwork Italian Heritage by Kerasan has the right to make any change to improve its products anytime; weights and sizes are for information only. The tonalities on sanitary ware are subject to light alterations due to the peculiarity of the production process, the alterations have to be considered as tolerance. The settings have been realized for aesthetic use only, they just suggest interior bath decorations.

artwork
ITALIAN HERITAGE
BY
KERASAN

ARTWORK ITALIAN HERITAGE by KERASAN
Via A. Einstein, 3
01033 Civita Castellana (VT) - ITALY
Tel. (+39) 0761 542018 (ra) - Fax (+39) 0761 540627
www.artworkitalianheritage.it